



Northwest Marine Technology, Inc.
Fish Marking and Tagging Systems
www.nmt.us

**AutoFish SCT
Operators Manual
2007**



4201 Airport Way
Anacortes, WA 98221
USA

TABLE OF CONTENTS

Introduction	7
AutoFish SCT Overview	9
Initial AutoFish Trailer Setup.....	11
Positioning the AutoFish Trailer	11
Moving the AutoFish Trailer.....	11
Leveling the AutoFish Trailer	11
Connecting the AutoFish Trailer to Power.....	12
Main Water Pump.....	13
Rinsing the AutoFish Trailer	14
Fish Health and Care	15
Feeding Fish	15
Fish Handling and Transport.....	15
AutoFish Sorter Software Operation.....	17
Software Overview	17
Startup	18
AutoFish Sorter Window.....	18
Sorter Port Adjustments	18
Length Distribution Window.....	20
Sorter VE Window	20
Sorter Images Window	21
System Feed	21
Turning On and Off the Fish Pump.....	21
Main Batch	22
Reviewing Images	23
Sorter Setup	24
Disinfect Mode	27
Lift Control.....	27
Reset User Batch	30
Sample	30
Sorter Data.....	32
Shut Down.....	35
AutoFish Sorter Components.....	37
Main Trough and Crowder	37
Sorter Volitional Entry (VE)	37
Fish Pump and Valve.....	38
VE Camera and Light.....	39
Sorter Camera and Backlight Chute	39
Backlight Chute Cover	40
Sorter Distribution Pipe Manifold.....	40
Sorter Water Flow and Sorter Booster Pump	41
Valve Boxes and Diverter Hardware.....	42
Wire and Water Jet Aperture.....	44

AutoFish Line Software Operation.....	47
Software Overview.....	47
Startup.....	47
Supervisor.....	47
Line Controller.....	49
Image Processing.....	55
Marking and Tagging Errors.....	59
AutoFish Line Components.....	63
Volitional Entry (VE).....	64
Gate Channel.....	64
Line Control Box.....	66
Adipose Fin Clipping Assembly.....	71
Imaging System.....	72
Fish Clamping Area.....	73
Water Flow Meters and Valves.....	74
Line Base.....	74
Mark IV (MKIV).....	75
Quality Control Device (QCD).....	77
Preparing the Sorter and the Lines to Process Fish.....	81
Leveling the Lines and Sorter.....	81
Water Flow.....	81
Determine Fish Size for Setup.....	82
Using the Handheld Controller.....	85
Setting up the Marking and Tagging Lines.....	89
Preparing the Lines for Fin Clipping.....	91
Preparing the Lines for Operation.....	93
Production in the AutoFish Trailer.....	95
Processing Fish.....	95
Fish Processing Errors.....	98
Processing Fish from the Reject Containment Systems.....	102
AutoFish Maintenance.....	105
Daily Maintenance.....	105
Winter Daily Maintenance.....	105
Weekly Maintenance.....	105
Annual Maintenance.....	106
Disinfecting the AutoFish Trailer.....	109
Disinfecting Procedures.....	109
Preparing the AutoFish Trailer for Transport.....	111
Emergency Procedures.....	113
Loss of Power and/or Water.....	113
AutoFish Trouble-Shooting.....	115

Appendices 129
Appendix A: AutoFish Spare Parts Order List 129
Appendix B: AutoFish Recommended Spares Parts and Accessories 135
Appendix C: Index 137
Appendix D: Contacting NMT 141

Introduction

In 1995, Northwest Marine Technology (NMT), in cooperation with the Washington Department of Fish and Wildlife and the Bonneville Power Administration began developing a series of machines to automatically inject Coded Wire Tags (CWT) and excise the adipose fin on salmonids. Through consistent research and development, NMT created an automated adipose clipping and tagging system which relies on the instinctual behavior of juvenile salmonids to move themselves through the tagging and/or marking process. This system requires minimal human handling and no anesthetic.

Northwest Marine Technology combined the clipping and tagging technology with automated sorting and created the SCT; a mobile sorting, clipping, and tagging system that has proven to be a valuable and reliable means of clipping and tagging for salmonids. Please take time to read and understand the operating and maintenance instructions so you can obtain the maximum performance from these products.

The AutoFish System is backed by a one-year parts and labor warranty. NMT takes pride in providing the best customer service and your complete satisfaction is important. Please contact us with any questions or comments about our products.

AutoFish SCT Overview

The following is an overview of how fish travel through the SCT system. The process will be described in much greater detail throughout the manual.

1. The fish pump delivers fish from the main holding trough to the sorter volitional entry (VE).
2. The dual exited sorter VE stages fish for entry into the imaging area.
3. The transition area between the VE and the imaging area each contain a set of wires and water jets which help create separation between individuals.
4. The fish slide through one of the two V-shaped chutes where they are measured to the nearest 0.10mm.
5. The fish is then diverted to the correct port according to their total measured length and sent to one of the line VEs.
6. The fish enter the water filled gate channel.
7. The sensor at the upper gate detects the fish which then triggers the upper gate to open.
8. When the fish is about half way through the upper gate (as determined by a further downstream sensor), the spring-tensioned gate begins to close in order to keep the next fish in line from being released.
9. There is now a single fish at the lower gate and several fish lined up behind the upper gate.
10. The single fish is released from the lower gate and slides into the clamping area where the fish's snout enters the head mold and triggers the nose sensor which is attached to the head mold.
11. The triggering of the nose sensor indicates that the fish is in proper position for processing and the fish adapter plates move into the closed position. The closed adapter plates properly position and securely hold the fish for processing.
12. The camera takes an image and the computer locates the adipose fin. This picture is called the Find Fin Image.
13. The marker is directed to the fin position designated by the computer and clips the fin.
14. A Coded Wire Tag (CWT) is implanted simultaneously when in tagging mode.
15. Another image is taken by the camera to determine what percentage of the total fin has been removed. This picture is called the Verify Mark Image.
16. The adapter plates and the trapdoor open to release the fish into the Quality Control Device (QCD).
17. The QCD verifies the presence of a tag and/or receives mark verification information from the computer and diverts the fish to either the hatchery receiving pond or to the reject containment system.
18. All data is compiled within the computers and displayed on the touch screen.

Initial AutoFish Trailer Setup

Positioning the AutoFish Trailer:

Typically, the trailer is set up near the ponds the fish are being taken from with the fish door located near the pond. Fish can easily be transported from the trailer back to the destination pond using irrigation pipe.

Things to consider when positioning the trailer:

1. The trailer is supplied with 250 feet of power cord. Position the trailer within this distance of the power source.
2. The trailer is supplied with 50 feet of pump cord and hose. Position the trailer within this distance of the water source.
3. The trailer outflow must be positioned higher than the destination pond wall.

Moving the AutoFish Trailer:

After the trailer is delivered to the hatchery grounds, it may be necessary to move the trailer into the desired position. The following are three methods which may be used to transport the trailer.

1. Fifth wheel: The tow vehicle is equipped with a special plate in the bed with a slot that the pin fits into and locks into place. This is a road legal method of transporting the trailer.
2. Gooseneck: The gooseneck is a 12" adapter which is bolted onto the fifth wheel pin. This piece mates with a 2 5/16" tow ball located directly over the rear axles of the tow vehicle. This is also a road legal method of transporting the trailer.
3. Ranch hitch adapter: The ranch hitch is a 23" adapter which is bolted onto the fifth wheel pin. This piece mates with a hitch receiver using a 2 5/16" tow ball on the rear receiver of a pick up. This is not a road legal method of transporting the trailer and should only be used for moving the trailer short distances on hatchery grounds.

Once the trailer is moved into position, lower the front jacks into position and lock both pins to hold them securely in place. Raise the trailer, open the tailgate, and remove the tow vehicle. Lower the front of the trailer enough to lower the rear jack stands into position. The jacks provide stability to the trailer during operation and take some of the weight off the tires and axles. Now the trailer may be leveled as described in the following section.

Leveling the AutoFish Trailer:

The trailer should be positioned to slope slightly towards the wall opposite the side doors and slightly from the front to the rear of the trailer. This allows for easier cleanup and keeps the floor dry throughout the day. Planks may have to be placed under one or both sets of tires to get the trailer sloped properly.

Connecting the AutoFish Trailer to Power:

The AutoFish trailer requires single phase, 220-240 volt, 60 amp, and AC power. It is important to make sure the hatchery power supply is consistent with the given requirements.

Once the trailer is positioned, ensure that the main circuit breaker is in the off position. There are three 83' power cords per trailer. The cord with the red connectors will connect directly to the trailer and the hatchery unless the extensions are needed. If the extensions are needed plug the extension cords into to the trailer first. Next, connect the extensions to the red cord, and last, plug the red cord into the service at the hatchery. It is an important safety precaution to plug into the hatchery receptacle last. Do not drag the cord connections on the ground. This may damage the threads on the connectors and make it difficult to attach cords. Keep any power cord connections dry.

Once the trailer is plugged into the hatchery power supply, check the reading on the volt meter inside the trailer. The volt meter should read between 220 and 240 volts. If the reading is between the required parameters, the main breaker may be switched to the on position.

To operate the system at a 208 volt facility, the trailer must be equipped with a transformer in order to safely operate the Flygt pump. If the volt meter indicates that the voltage is lower than 220 volts, the transformer must be switched to the 208 setting. This transformer should be switched back to the 220 volt setting prior to operating at a 220 volt facility.

The system is equipped with a circuit that protects the trailers electrical system from improper voltage. Improper voltage may result from miss-wired power connectors or from connecting the system to something other than the required power. If the power is within the required range (+ or - 10%), the voltage sensing relays will energize the main contactor which will provide power to the distribution panel. If the power does not fall within the given range, the main contactor will not be energized and there will be no power available to the distribution panel.

The computer cabinet houses the power supplies and the computer system for the lines and the sorter. This includes three 12 volt power supplies for the touch screens and one 24 volt power supply for each of the lines and the sorter (Figure 1). Once the main breaker is switched on, the power distribution board sends power to the appropriate locations.

Turn on the Uninterrupted Power Supply (UPS) located next to the computer cabinet. The UPS should remain on for the duration of the project in order to keep the battery charged in case of a power loss. The UPS protects the computers from momentary power problems. If there is a power loss, the UPS can keep both of the computers supplied with power for approximately 20 minutes. Before unplugging the trailer from the hatchery power supply, turn off the UPS.

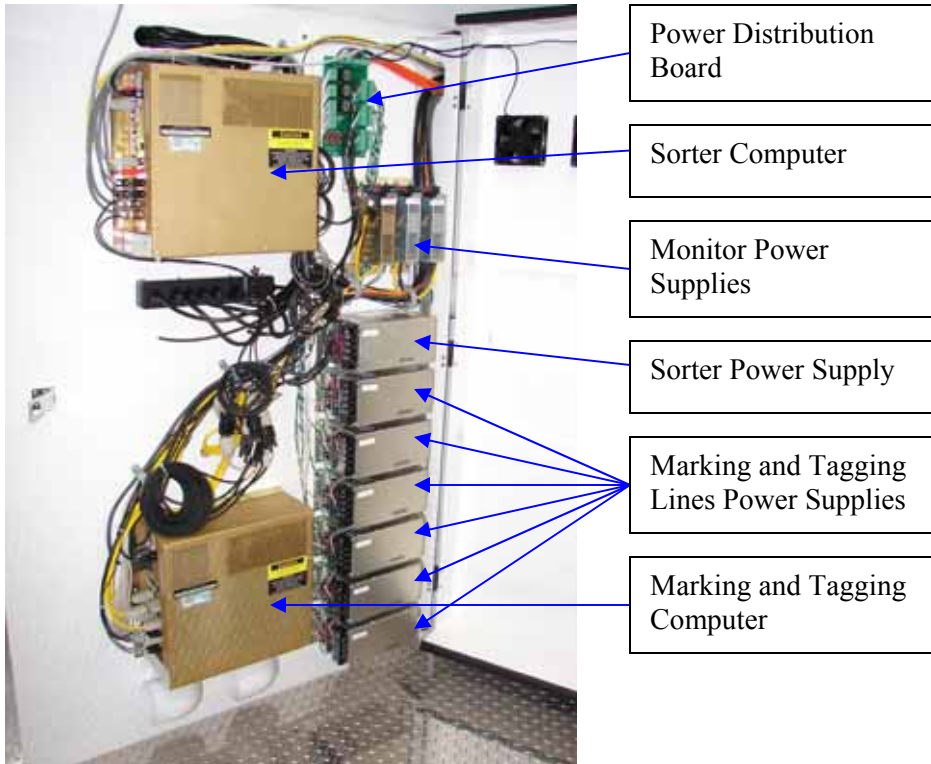

Figure 1: Computer Cabinet

Main Water Pump:

The main water pump is a triple-phase Flygt model and supplies approximately 200 gpm at 30 psi. The pump should always be operated in a vertical position relative to its axis. There is a mercury switch located internally that will shut the pump off if attempted to run on its side. The pump is oil cooled and the oil must be in the reservoir in the bottom of the pump to cool it sufficiently. An owner's manual is supplied in each trailer.

★Positioning the Main Water Pump

Things to consider when positioning the water pump:

1. The trailer is supplied with 50 feet of pump cord and hose. The pump must be positioned within this distance.
2. Place pump in a pond that is not going to be drawn down. Make sure screen is intact and that there are no fish behind the screen (pump will suck up fish and clog strainers). If the pump has to be placed within a pond containing fish, place it in a screen bucket with a cover so fish do not get sucked into the pump.
3. Suspend the pump in the water column so it does not sit on the pond floor and suck in sand or silt.
4. Position the pump and pump hose as to not interfere when transporting fish to the trailer.

Rinsing the AutoFish Trailer:

Before turning on the pump to rinse the trailer, ensure that any water that will drain from the trailer cannot run into a pond or drain into any other water source. The discharge water may contain some bleach residue. It is sometimes necessary to use irrigation pipe to transfer rinse water to the appropriate area.

1. Open all valves and flow meters so freshwater can flow through any pipe and hose that may contain bleach water.
2. Plug in the air compressor to the fitting located on the front of the trailer.
3. Turn on both of the computers (make sure the UPS is on).
4. Move the crowder up to the fish pump intake and place all loose submersible equipment into the trough behind the crowder.
5. Turn on the main pump switch.
6. Once the trough is full of water turn on the sorter booster pump.
7. Turn on the line booster pump.
8. Place the marking and tagging software in disinfect mode to activate the fin washer and the fish ejection solenoids.
9. Place the sorter software in disinfect mode to activate the water jet solenoids.
10. Open the sorter setup menu in the sorter software and click on test ports to activate both diverters for approximately 30 seconds to divert water to all lines.
11. Turn the System Feed on to actuate the fish valve and to operate the fish pump.
12. Allow trailer to rinse for approximately 15 minutes.
13. During this time, take the trailer wash-down hose and rinse all parts inside the trailer. Rinse the VEs, QCD & hoses, lines, walls, floor, back tagging table, etc.
14. Press STEP/ SHOW on the MKIV to activate the diverter gates.

After the trailer and all accessories have been rinsed, the AutoFish trailer is ready to set up for operation mode!

Fish Health and Care

Feeding Fish:

It is critical that the pond of fish being tagged be off feed for at least 24 hours prior to tagging. There are several reasons for this:

1. Reduces the stress on the fish when handled.
2. Starved fish run through the marking and tagging lines smoother.
3. Feeding fish can reduce the dissolved oxygen.
4. Handling fish that have been fed may result in regurgitation of feed.

When working with large groups of fish, use a crowder to split the pond and let the hatchery feed the fish behind the crowder.

Fish Handling and Transport:

Fish can be transported directly to the trailer using dip-nets or buckets. If the trailer is within 15 feet of the pond, the fish can be transported directly to the trough using a dip-net. If the trailer is more than 15 feet from the pond, buckets can be used to safely transport fish in water.

After tagging, fish can be transferred long distances through irrigation pipe to the destination pond. Make sure the irrigation pipe is stable and has plenty of fall. At the end of the day, flush the irrigation pipe thoroughly. The trough may have to be filled several times to flush the line out. Slowly pull the trough sump, open the main valve (under trough) and flush it through the outflow pipe to insure all fish have been removed. Depending on the slope of the trailer and the height of the outflow pipe, the trough may have to be drained very slowly. If caution is not taken, fish and water may back up in the outflow pipes and result in overflows.

AutoFish Sorter Software Operation

Software Overview:

The sorter is controlled by software through a conventional PC using Windows XP operating system. This program is started by double clicking the sorter icon on the desktop and must be shut down following the shutdown procedure described in the following section. There are six main windows displayed during sorting: the main AutoFish Sorter, Length Distribution, Sorter Images, Sorter VE, Sorter Data, and Lift Control window. These windows work in conjunction to control the fish lift and the entire sorting device.

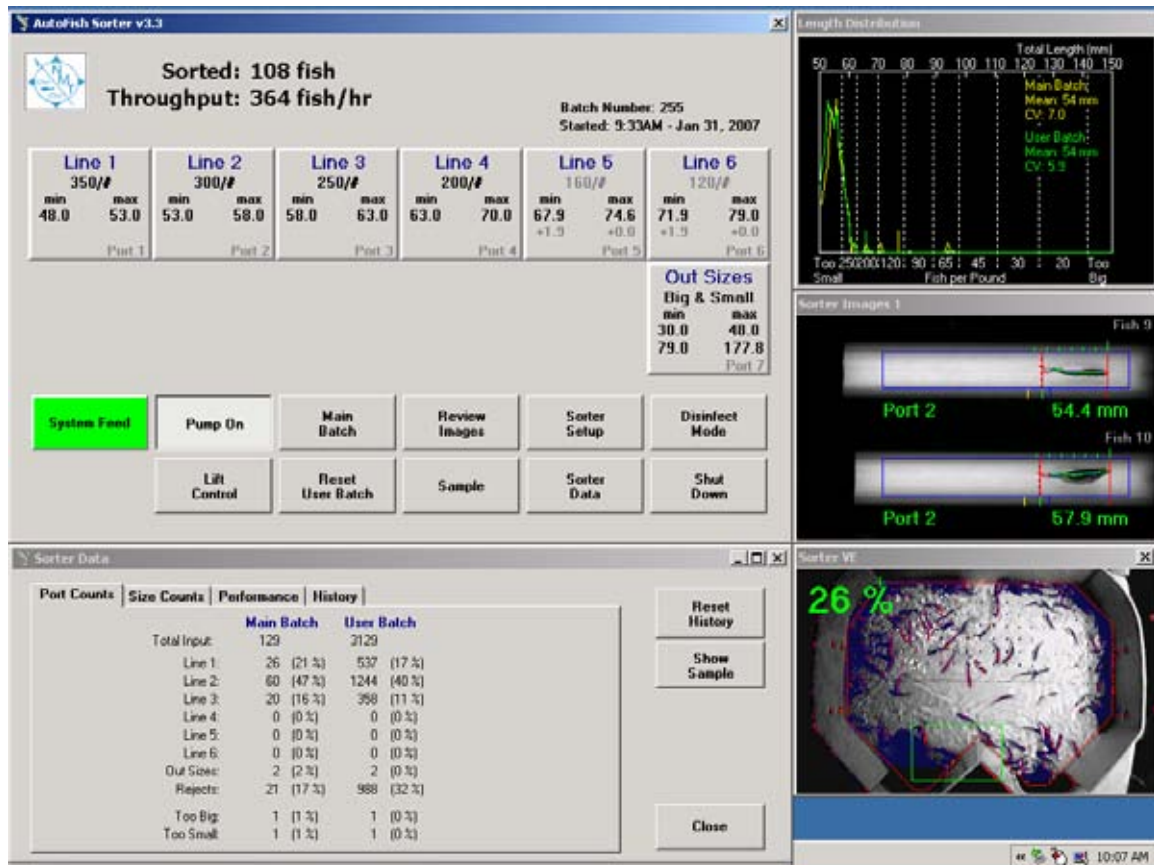

Figure 2: AutoFish Sorter Software

Startup:

Using the green power switch labeled ‘Sorter’ on the front wall of the trailer, turn the power on to the sorter computer. When the computer is turned on, double click the sorter icon to start the necessary sorting software.

AutoFish Sorter Window:

The title bar of the main AutoFish Sorter window displays the current version of software. The AutoFish Sorter window contains the total number of fish sorted and throughput for the current batch. Also located within this window is the port information which provides the ability to change the configuration of each port. Positioned at the bottom of the main sorter window are two rows of command buttons that aid in the navigation through the sorter’s many capabilities.

Sorter Port Adjustments:



min	max
68.0	74.6
+2.0	+0.0

Line 1
160/#
Port 1

The sorter port adjustments are located on the main sorter window. Each of the eight sorter ports (Figure 2) must be configured to accept the size of fish that corresponds to each marking and tagging line. Each of the first six sorter ports is set up to match the sizes of the six marking and tagging lines. The remaining two ports are configured for rejects and out-of-size fish. To configure a port, follow the proceeding steps.

1. Double click on the desired port. This will bring up the Port Control Setup window (Figure 3) which will allow you to select the port label and the fish size for that port.
2. Once a size is selected, the default settings for the minimum and maximum length will appear.
3. Adjustments to the minimum and maximum length settings can be made by changing the default settings for each line port. This is accomplished by clicking on the length override arrows. Values can be adjusted to the tenth of a millimeter. When the default settings are changed, the adjusted length will be displayed in grey below the minimum and maximum.
4. The minimum and maximum length settings can be returned to default at any time by pressing the ‘Reset’ button.
5. After adjustments are made, the Port Control Setup window can be closed and changes saved by touching the ‘OK’ button. If the operator does not wish to save the current changes made, the ‘Cancel’ button will abandon all changes made during that operation.
6. The ‘Out Sizes’ port is used for fish that are outside the size parameters being processed. This port will automatically set the appropriate size ranges for fish that are too big or too small.
7. If ports are configured in a manner that fish of a certain size range are not included, the reject warning window (Figure 4) will appear. This window displays exactly which sizes will be rejected according to the current configuration.
8. During normal operational mode, any port may be closed to fish by clicking once on the desired port. The fish will then be diverted to other same-size ports or if there is no same-size port, the fish will be sent to the reject port. The port will appear red in this mode. Clicking once on it again will return the port to normal operational mode.

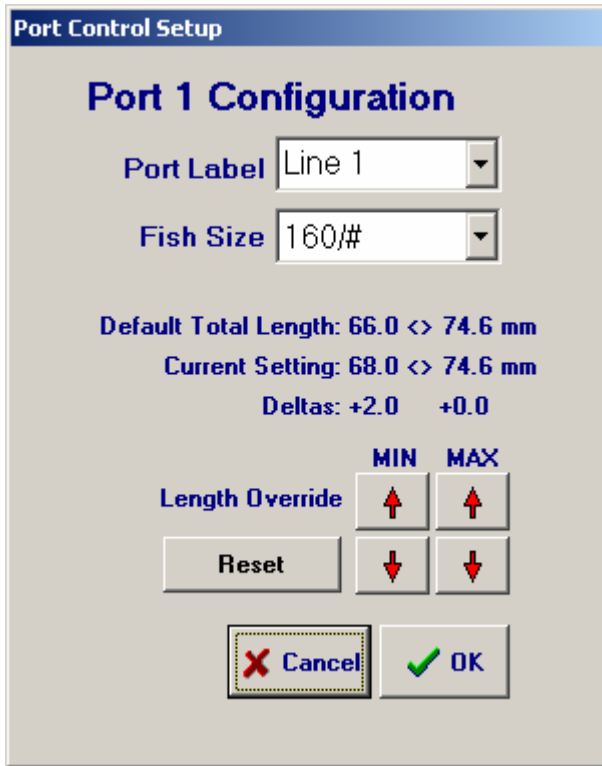
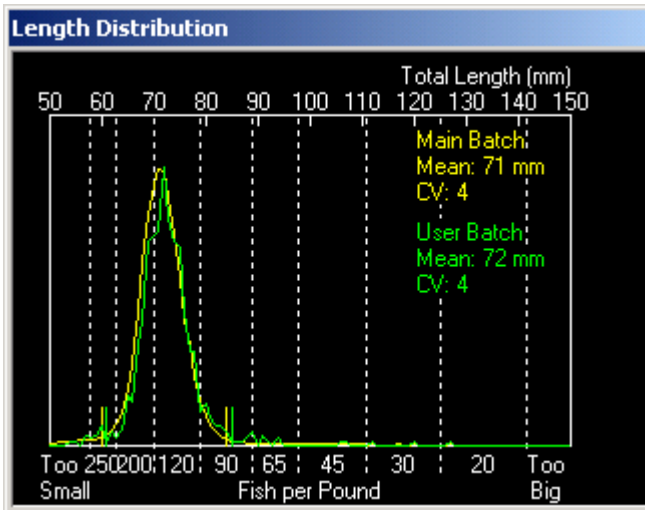

Figure 3: Port Control Setup



Figure 4: Reject Warning Window

Length Distribution Window:



As the fish are being sorted, the computer generates a length distribution curve and displays that data in the 'Length Distribution' window. There are two curves displayed in this window; the Main Batch and the User Batch data. Both will continue to compile until manually reset. Total Length in millimeters is displayed along the top axis and fish per pound is displayed along the bottom axis. This window also displays the mean length of the fish and the coefficient of variation (CV) for the Main Batch and the User Batch data.

Sorter VE Window:

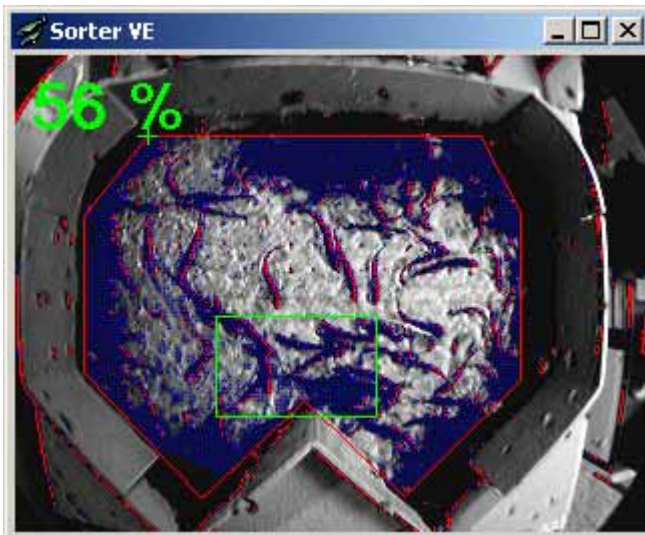

The Sorter VE window displays a live image of the sorter VE. The sorter software uses this image to determine the density of fish within the VE and displays the current percentage in the upper left-hand corner. The sorter software uses this information to determine when to open the valve and pump fish into the VE when the system feed in on. The red outlined area is the area in which the computer searches to determine the density. This area is adjustable in the event there is a change to the perimeter of the VE and is explained in the Imaging section. The gain, which controls the brightness for

the sorter VE camera is auto adjusting. The camera utilizes the area within the green box to gauge necessary gain adjustments.

Sorter Images Window:

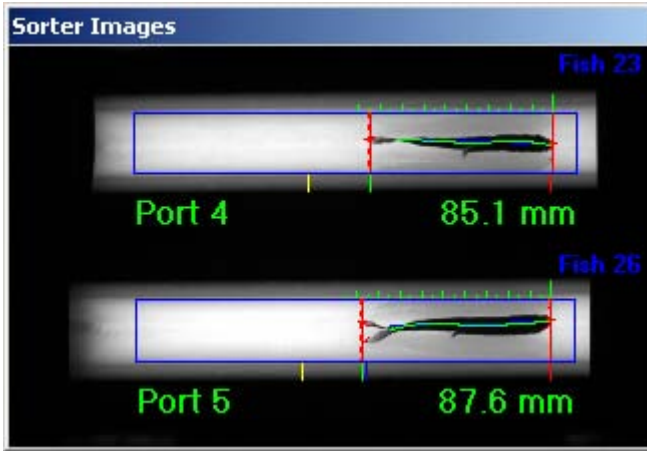

The Sorter Images window displays the last fish image for each channel, the measured length of each fish, and the corresponding port. Each fish image contains two solid red lines; one located at the snout of the fish and the other at the end of the tail. The curve of the fish is displayed as a lateral green line through the center of the fish. Using an algorithm, the computer corrects the curvature of the fish which is displayed as a blue line. The red dotted line behind the fish is a display of how much length the computer added to the fish

after the curl correction. To view this in more detail, the Sorter Images window can be enlarged. Touching the window once will enlarge the images and touching it a second time will return it to the normal size.

System Feed:

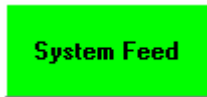

The 'System Feed' button is located on the main sorter screen as shown in Figure 2. To initiate the valve and pump to move fish into the sorter VE, press the 'System Feed' button to the on position. When the System Feed is on, the button will be colored green. To turn the system feed off, press the 'System Feed' button again. When the System Feed is off, the button will be colored red.

Turning On and Off the Fish Pump:



The main power for the fish pump is controlled with a green switch located on the front wall of the trailer. The main power for the fish pump must be on prior to starting the Lift software. Once this switch is turned on, the fish pump may be started by pressing the 'Pump On' button located on the main sorter screen shown in Figure 2. To turn the fish pump off, press the 'Pump On' button again. When the pump stops running, the green power switch may be turned off.

Main Batch:

Main Batch The main batch data and distribution curve will continue to compile until it is manually reset. The 'Main Batch' button opens the 'Batch Operations' window (Figure 5) containing several options for the main batch data. The 'Print and Reset' button will clear all the recorded fish data and print a Batch Report that contains all the size data and a distribution curve for that batch. The 'Reset Batch' button will clear all the recorded fish data but will not print a Batch Report. A Batch Report may be printed without clearing the recorded fish size data by pressing the 'Print Open Batch' located in the Batch Operations window. Any previous Batch Reports may be printed by pressing the 'Print Old Batch' button located in the Batch Operations window. Use the arrow keys (Figure 6) to move to the desired batch number and press the 'Print' button. The number associated with the batch file corresponds to the date the batch was closed and is in the form YYMMDD.

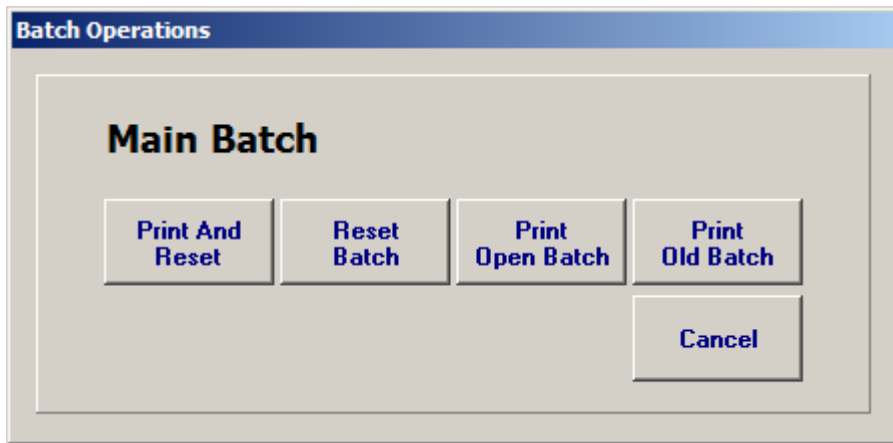

Figure 5: Main Batch Operations Window

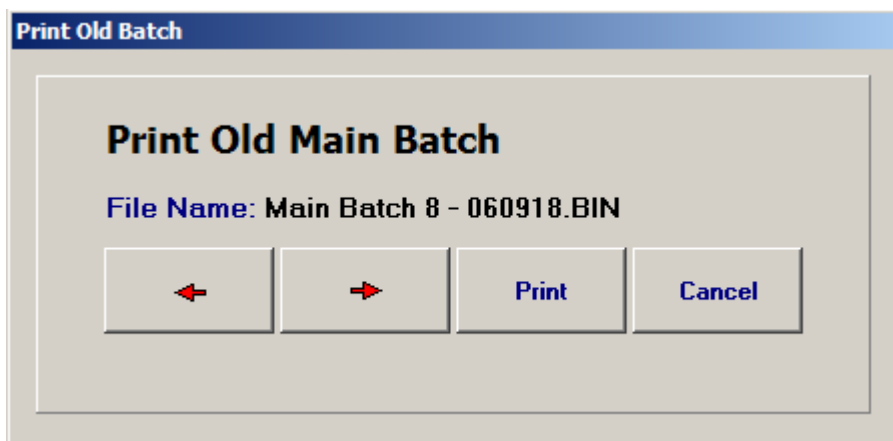

Figure 6: Print Old Batch Window

Reviewing Images:

Review Images

The sorter software stores the last 100 images processed. While sorting, the images are moving so quickly that it is difficult to view the details of any one image. For this reason, image review is used to freeze images for review. This option is located on the main sorter screen shown in Figure 2. Press the 'Review Images' button and scroll through the images using the directional arrows shown in Figure 7. Each fish is assigned an Image Number and the results of the measurement are displayed in the Results section. The measured length is the actual measured length of the fish. The corrected length is the length of the fish after the curl factor and slope are calculated and added. The Results section also displays which port the fish was sent to. Another option within this window is to save any particular fish image for further analysis. By pressing the 'Save' button, the image displayed on the screen will be saved to the computer's hard drive. Press the 'Close' button to close the Review Image History window.

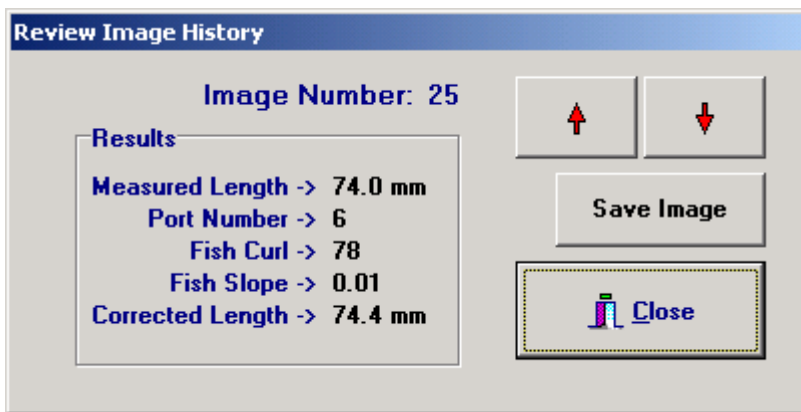

Figure 7: Review Image History

Sorter Setup:

Sorter Setup The 'Sorter Setup' button is located on the main sorter window as shown in Figure 2. The Sorter Setup window contains all of the adjustments for the imaging and diverter aspects of the sorter. As described below, the sorter image can be adjusted, calibrated, and the sensitivity adjusted in this window. Also located in this window are features to adjust the diverter timing and test the diverter for proper operation.

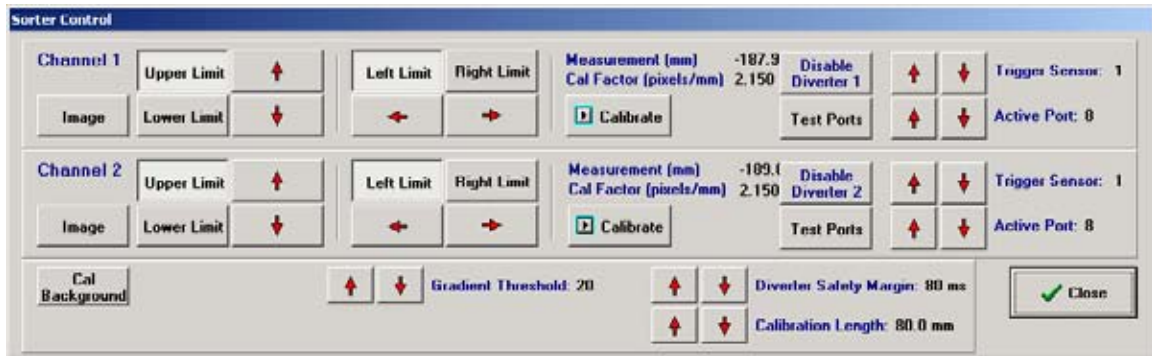

Figure 8: Sorter Setup Window

★Region of Interest

The Region of Interest (ROI) is the area in which the sorter computer searches for the fish to be measured. There are two Regions of Interest; Channel 1 corresponds to the upper sorter image and Channel 2 corresponds with the lower sorter image. The two Regions of Interest are displayed as blue rectangles around each of the sorter images, as shown in Figure 9.

The Regions of Interest can be adjusted to maximize the area in which the computer searches for fish. There are two sets of buttons used to adjust the Regions of Interest both of which are located in the upper left corner of the 'Sorter Setup' window shown in Figure 8. The set of buttons labeled Channel 1 adjust the upper sorter image and the set of buttons labeled Channel 2 adjust the lower sorter image. The top and bottom limits of the ROI are adjusted by pressing the 'Upper Limit' or 'Lower Limit' button, and making the necessary changes with the adjacent arrow keys. Similarly, the right and left limits of the ROI are adjusted by pressing the 'Left Limit' or 'Right Limit' button, and making the necessary changes with the arrow keys below the buttons.

★Image

Image Slight adjustments may be made to the location of the sorter images using the 'Image' button located in the Sorter Setup window (Figure 8). Press the 'Image' button and using the ROI up and down arrow keys adjust the image to the desired location. Once the image has been moved, the computer will prompt that it is necessary to re-calibrate the background.

★Sorter Calibration

The sorter is calibrated using a calibration rod measuring 80mm in length. This tool provides the imaging system a standard sized object to base the calibration on as shown in Figure 9. Calibration is only required after trailer movement or when a problem is suspected. To calibrate, follow the subsequent steps.

1. Turn off all water to the sorter including the VE, transition, and the water jets.
2. Press the 'Sorter Setup' button on the main sorter software screen.
3. Place the calibration rod in the center of the camera's field of view in channel 1.
4. Ensure that the imaging system is accurately finding both ends of the calibration rod.
5. Press the 'Calibrate' button for channel 1 and verify that the measured length is 80 mm.
6. Remove the calibration rod and repeat the procedure for channel 2.
7. Press the 'Close' button to return the software to normal operation mode.

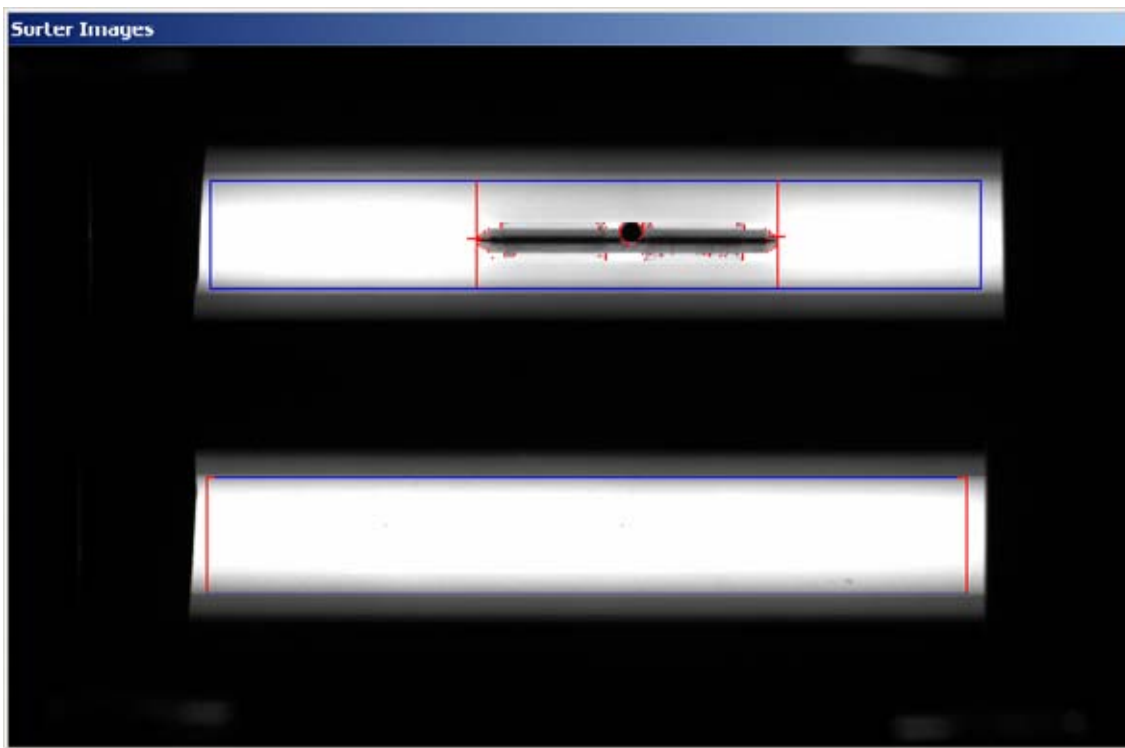

Figure 9: Sorter Calibration Image

★Calibrate Background

Cal Background When an adjustment is made to the sorter camera focus or F-stop, or a change is made to the image, the imaging background must be re-calibrated. During background calibration, the computer stores an image of the backlight image to use for comparison during sorting. To calibrate the background press the 'Cal Background' button located in the Sorter Setup window shown in Figure 8. During background calibration, it is important that the water flow is set at a normal rate and that no fish are moving through the imaging area.

★ Gradient Threshold

The Gradient Threshold adjustment, located in Sorter Setup (Figure 8), is used to adjust the edge detecting sensitivity of the sorter images. The arrow keys to the left of the Gradient Threshold are provided to adjust this setting. Increasing the Gradient Threshold number makes the system less sensitive to “noise” in the image, such as particulate matter and water drops, but also makes the system less sensitive to detecting the edges of translucent tails. Decreasing the number will increase the detecting sensitivity of the system. If the Gradient Threshold is set to high, the imaging system may miss the fish tail and measure the fish at the peduncle. If the Gradient Threshold is set too low, the imaging system may measure anomalies within the image.

★ Diverter Safety Margin

The Diverter Safety Margin is located in the Sorter Setup window (Figure 8) with a default setting of 80. The Diverter Safety Margin is the measured time between when one fish has left the imaging area and the next one enters the imaging area and is measured in milliseconds. If this time parameter is violated by the second fish, it will result in an unsafe hold. Arrow keys are provided to adjust the Diverter Safety Margin. Decreasing the value will make the diverter system more aggressive, which could lead to fish getting hit by the diverter gates. Increasing the value will make the system less aggressive, which may increase the number of unsafe holds.

★ Calibration Length

The calibration length and the length adjustment keys are displayed in the Sorter Setup window (Figure 8). The calibration length should always be set at 80.0 mm when using the supplied calibration rod to calibrate the sorter. In rare cases, when the calibration rod cannot be used, the calibration length may need to be adjusted to the length of the device being used to calibrate.

★ Test Ports

Test Ports

The Test Ports feature is used to cycle the air cylinders on the diverters. Before fish are run through the sorter system, the diverters should be tested using the Test Ports option. This choice is selected by pressing the ‘Test Ports’ buttons in the Sorter Setup window (Figure 8). There is one button for each diverter. Once initiated, the air cylinders will engage sequentially and the user may ensure proper diverter operation. In order to return to normal operation mode, press the ‘Test Ports’ button again.

★ Disable the Diverter

Disable Diverter 1

The Disable Diverter feature is located in the Sorter Setup window, shown in Figure 8. When the ‘Disable Diverter X’ button is pressed, all the air cylinders will be retracted for that particular diverter. Prior to disabling the diverter, the fish flow to that particular channel must be stopped. To re-enable the diverter and resume sorting, press the ‘Disable Diverter X’ button again and open the fish stop gate.

★ Individual Port Test

Located in the ‘Sorter Setup’ window is an option to individually actuate any port on either diverter. As shown in Figure 8, the active port and arrow keys are displayed on the right hand side of the window for each diverter. To actuate a specific port, press the corresponding arrow button on the screen until that port is active and that particular cylinder will extend.

★Trigger Sensor

Situated just past the wire aperture is a series of three IR sensors that are used to activate the water jets. Once the fish has blocked the chosen sensor, the water jets will actuate to aid in fish separation. Once the fish has cleared the sensor and light is again transmitted, the solenoid will close and the jets will turn off. The adjustment for the trigger sensor that activates the water jets is located in the 'Sorter Setup' window as shown in Figure 8. The trigger sensor is adjustable from 1 to 3 depending on the fish size. The adjustments are made using the arrow keys located to the left of the trigger sensor display. There is one trigger sensor adjustment for each channel.

Disinfect Mode:



The disinfect mode is used during disinfection and rinsing procedures. This mode opens the solenoid to the water jets so that bleach water or rinse water can flow freely through the solenoids. To initiate this mode, press the 'Disinfect Mode' button located on the main sorter screen shown in Figure 2. Pressing the 'Disinfect Mode' button a second time will return the solenoids to normal operation mode.

Lift Control:



All controls for the fish pump, fish valve, and sorter VE imaging are located in the 'Lift Control' window. This window is displayed by pressing the 'Lift Control' button located on the main sorter screen shown in Figure 2. The Lift Control window consists of several components: the main window, the Fish Valve tab, the Imaging tab, and the Fish Valve Setup tab.

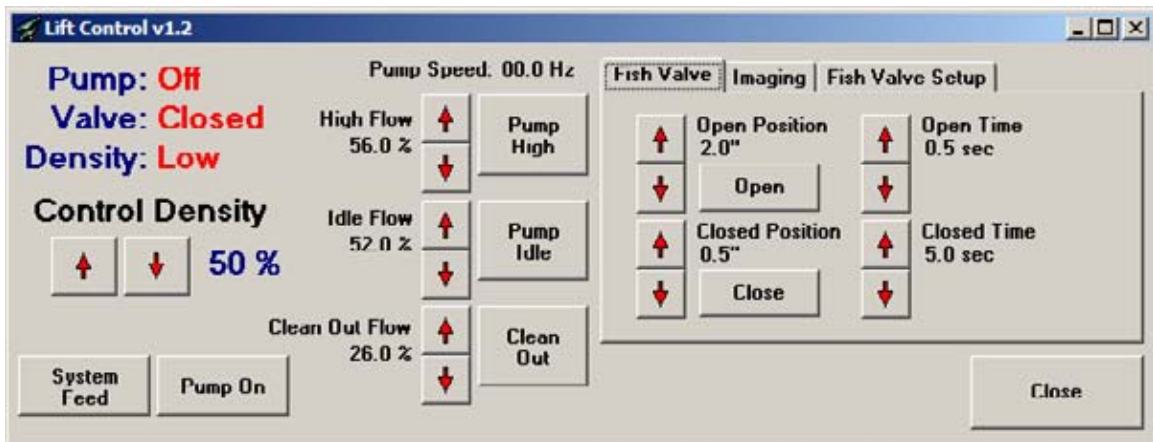

Figure 10: Lift Control Window

★Lift Control

The title bar on the Lift Control window displays the current version of the Lift software.

The adjustment for the Control Density is located in the Lift Control window. The Control Density controls the amount of fish in the sorter VE and is manually set by the operator. The software determines the density of the VE by comparing the amount of black (fish) against the white bottom of the VE. If the density is set at 50%, the System Feed will continue to pump fish to the VE until 50% of the VE is black. The Control Density is adjusted by using the arrow keys next to the density display as shown in Figure 10.

The Lift Control window displays information on the status of several mechanisms. The Pump, Valve, and Density status are displayed in the upper left hand corner of the Lift Control window. Once the System Feed is on, if the density in the sorter VE drops below the set Control Density (Low), the fish pump speed will increase to high and the fish valve will open. Once the density in the VE meets or exceeds the set Control Density (High), the valve will close and the pump will return to idle speed.

The Lift Control window also contains several controls for the fish pump. There are three buttons that correlate to the three speeds at which the fish pump operates: Pump High, Pump Idle, and Clean Out. With the System Feed off, pressing any one of these buttons will change the pump speed to that particular speed. The Clean Out option is a very low pump speed. The 'Clean Out' option is used to remove the pump hose from the de-watering device to ensure that fish do not linger in the pump housing. Do not disconnect the pump hose from the de-watering inlet unless the pump is off or running at the Clean Out speed. To the left of the pump speed buttons are the corresponding settings for each speed in terms of percentage of the range of the pressure sensor located on the outflow of the pump. These pump speed settings are adjustable using the adjacent arrow keys.

Also located in the Lift Control window are duplicate buttons for System Feed and Pump On.

★Fish Valve

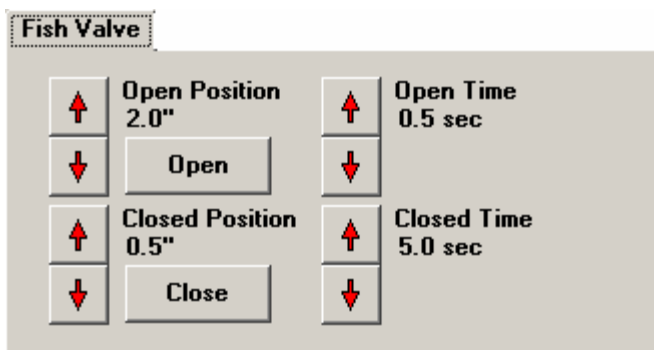

The Fish Valve tab contains the controls to adjust the fish valve settings. The Open and Closed position are displayed on the left side of the tab in inches. The adjacent arrow keys are used to adjust the open and closed position of the valve. With the System Feed off, the valve can be opened or closed by pressing the respective button in this tab. Also displayed within this tab are the times the valve stays open

and closed when cycling. These times are also adjustable using the arrow keys.

★ Imaging

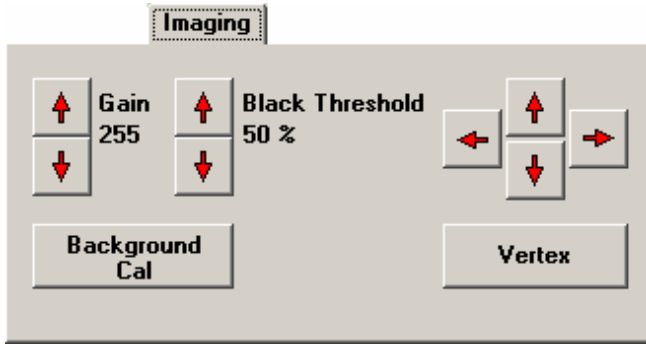

The adjustments for the lift imaging system are located in the Imaging tab. The sorter VE camera has an auto adjusting gain (brightness). The green box located in the Sorter VE image is the area that the camera utilizes to gauge the appropriate gain adjustments. Although the Gain is automatic, there is an option to make manual adjustments to the gain. This is accomplished by using the arrow keys next to the Gain

display. Manual gain adjustment may be needed, in rare cases, when there are drastic light changes near the sorter VE and the automatic Gain is adjusting too slowly.

The 'Background Cal' button is used to generate a calibration image of the VE. Before the background can be calibrated, the VE must be empty of fish and the water and light should be set as they would be in production mode. The calibration image can then be captured by pressing the 'Background Cal' button.

When determining the density of the VE, the computer compares the calibration image to the image of the VE with fish in it. The Black Threshold is the percentage that the pixels from the calibration image have to change (darken) in order to be considered black and be counted towards the density. The Black Threshold is adjustable by using the arrow keys to move the value up or down. If areas of the VE that don't contain fish are being detected and counted as fish, it may be necessary to move the Black Threshold percentage down slightly. Moving the Black Threshold percentage up will increase the detection of actual fish.

As seen in the Sorter VE image, the red outlined area is the area in which the computer searches to determine the density. If changes are made to the perimeter of the VE, the red outlined area can be adjusted to accommodate these changes. Each vertex of the red outline can be adjusted by pressing the 'Vertex' button until the desired vertex is highlighted with a green cross. Once the desired vertex is selected it may be adjusted using the four arrow keys located above the 'Vertex' button. The red outlined area can then be manipulated to the user's desired shape.

★Fish Valve Setup

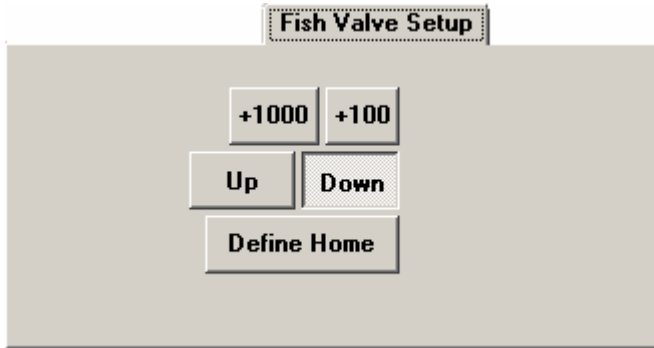

The Fish Valve Setup tab allows the user to mechanically move the valve up or down. This setting is also used for re-homing of the valve. To move the valve, it is necessary to first push the corresponding button for the direction desired. Once the Up or Down direction button is depressed, the valve can be moved by pressing the '+1000' or '+100' buttons. This will move the valve in the desired direction either

1000 or 100 steps. If the valve needs to be homed, move the valve to the desired home position (the valve home position is consistent with the closed position) and press the 'Define Home' button. If the valve is significantly out of home position, a 'Position out of Range' error may occur. The valve can only move 1000 steps down from the defined home position. Each time the 'Position out of Range' error occurs, press the 'Define Home' button in order to establish a new home position, and move the valve down to the closed position.

Reset User Batch:



The 'Reset User Batch' button is located on the main sorter screen (Figure 2). This feature will reset all the User Batch data that has been collected since that particular session has begun. It will also reset the User Batch curve in the Length Distribution window. The main batch data will continue to compile and no batch report will be printed.

Sample:



The Sample option allows the user to form a distribution curve without diverting fish to the marking and tagging lines during initial setup. All the fish going through the sorter during Sample mode will be diverted back to the main trough. This option is activated by pressing the 'Sample' button located on the main sorter screen as shown in Figure 11. The sorter software may be returned to normal mode by pressing the 'Sample' button again.

While the software is in the Sample mode, the phrase 'Sampling Histogram' will be displayed under the port information windows (Figure 11). This is to denote that the fish are being sent back to the main trough. In the Length Distribution window, the size curve for the sample fish is displayed in red, as shown in Figure 11. The 'Size Counts' and 'Port Counts' tabs in the 'Sorter Data' window will show the sample fish sizes and their corresponding ports when the 'Show Sample' button is depressed. At any time you may reset the sample data in these tabs by pressing the 'Reset Sample' button located on the right side of the window.

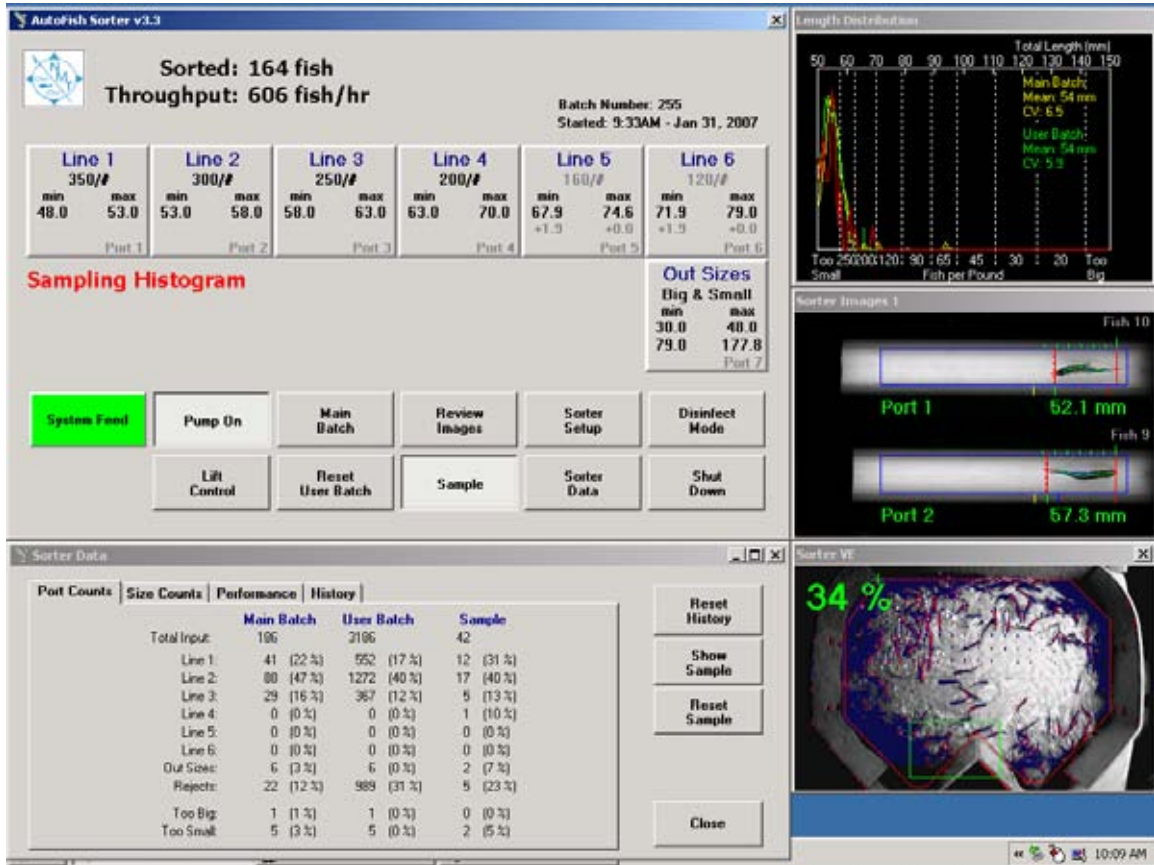

Figure 11: Sample Mode

Sorter Data:

Sorter Data The sorter throughput, errors, and the port count information are all displayed in the 'Sorter Data' window. The 'Sorter Data' window consists of a main window and four tabs within that main window: Port Counts, Size Counts, Performance, and History.

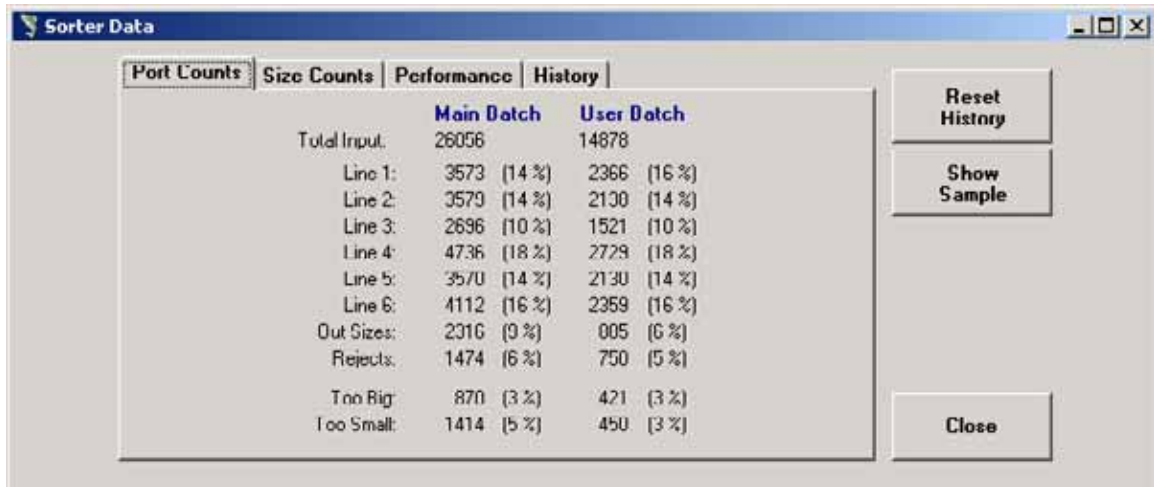

Figure 12: Sorter Data Window

★ Main Window

The main sorter data window, shown in Figure 12, contains three buttons located to the right of the data tabs. The 'Show Sample' button will display the fish sizes and corresponding ports while in sample mode. Also located in this window is a 'Reset History' button which will reset the throughput history graph. Located in the lower right hand corner is a 'Close' button that will close the Sorter Data window.

★ Port Counts

	Main Batch	User Batch
Total Input:	26056	14878
Line 1:	3573 (14 %)	2366 (16 %)
Line 2:	3579 (14 %)	2138 (14 %)
Line 3:	2696 (10 %)	1521 (10 %)
Line 4:	4736 (18 %)	2729 (18 %)
Line 5:	3570 (14 %)	2130 (14 %)
Line 6:	4112 (16 %)	2359 (16 %)
Out Sizes:	2316 (9 %)	885 (6 %)
Rejects:	1474 (6 %)	750 (5 %)
Too Big:	870 (3 %)	421 (3 %)
Too Small:	1414 (5 %)	450 (3 %)

The 'Port Counts' tab in the 'Sorter Data' window displays the number and percentage of fish going to each individual port. The data is separated into Main Batch and User Batch data. At the top is a 'Total Input' showing the total number of fish actually entering the sorter. Below the 'Total Input' data is a list of all eight ports and the number of fish that have been diverted to them. Located at the

bottom is the Out Sizes broken down into Too Big and Too Small.

★Size Counts

Size Counts			
	Main Batch	User Batch	
Total Sorted:	25155	14528	
Shorter Than 250/#:	127 (1 %)	62 (0 %)	
250/#:	777 (3 %)	405 (3 %)	
200/#:	7623 (30 %)	4206 (30 %)	
120/#:	13282 (53 %)	7930 (55 %)	
90/#:	2991 (12 %)	1655 (11 %)	
65/#:	291 (1 %)	145 (1 %)	
45/#:	58 (0 %)	39 (0 %)	
30/#:	3 (0 %)	3 (0 %)	
20/#:	2 (0 %)	2 (0 %)	
Longer Than 20/#:	1 (0 %)	1 (0 %)	

The 'Size Counts' tab in the 'Sorter Data' window displays the number of fish in each particular size range as defined by the default limits for each size and what percentage of the population they represent. The data in this tab is separated between Main Batch and User Batch.

★Performance

Performance				
	Session	Last Hour	Last 10 Minutes	Last Minute
Input (fish/hr):	6512	2768	6630	8400
Output (fish/hr):	6258	2660	6342	8100
Out of Size:	0 %	0 %	0 %	1 %
Shape Errors:	1 %	1 %	1 %	0 %
Ch 1 Multiples:	2 %	2 %	2 %	2 %
Unsafe Holds:	2 %	2 %	3 %	3 %
Throughput:	2534	1077	2532	3960
Ch 2 Multiples:	1 %	1 %	1 %	1 %
Unsafe Holds:	1 %	1 %	2 %	3 %
Throughput:	3978	1631	4098	4440

The 'Performance' tab records and displays all the throughput data for the session. The throughput is segregated into three time intervals: Last Hour, Last 10 minutes, and Last Minute. The data for each particular interval will remain red until that time interval has been attained. The first four sets of data in this tab provide a cumulative for channel 1 and channel 2. The input

measures the number of fish traveling through the channels measured in fish per hour. The output measures the number of fish that were successfully sorted to one of the six lines or the Out Sizes port in fish per hour. The 'Out of Size' data reports the percentage of fish that were measured and their measurement did not fall into the criteria for any of the ports. These fish are rejected and sent back to the main trough. During the imaging process, if the fish is out of shape and the curl and/or slope data is out of specifications, the fish will be rejected as a shape error (Figure 13). This data is recorded as a percentage in the Shape Errors section of this tab.

The second set of data in the 'Performance' tab is segregated between channel 1 and channel 2. During the imaging process, if there are two fish pictured in the image, they will be rejected as a Multiple as shown in Figure 14. These numbers are displayed as a percentage for each channel as 'Ch 1 Multiples' or 'Ch 2 Multiples'. 'Unsafe Holds' for each channel are also displayed on this tab. There is a specific amount of time required between fish to safely divert them. If two fish are too close and violate this time parameter, the diverter will hold in position and the second fish will go to the same port as the first fish. This case is displayed, under the fish image, as a yellow Unsafe Hold (Figure 15). If the Unsafe Hold is displayed in red, as seen in Figure 16, the resulting Unsafe Hold was rejected and sent back to the main trough. The last piece of data in this tab is the throughput for each channel displayed in fish per hour.

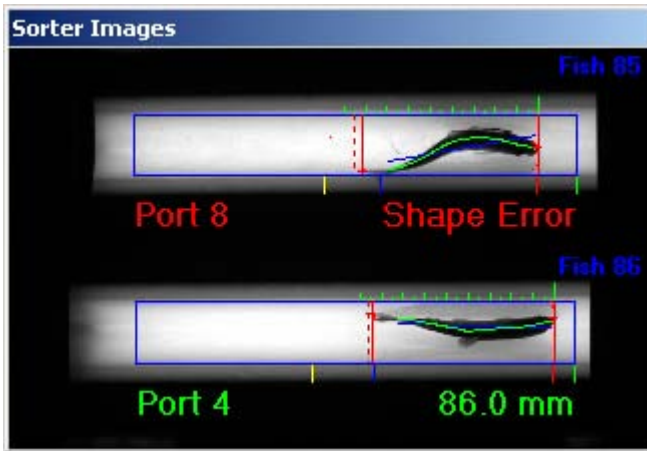

Figure 13: Shape Error

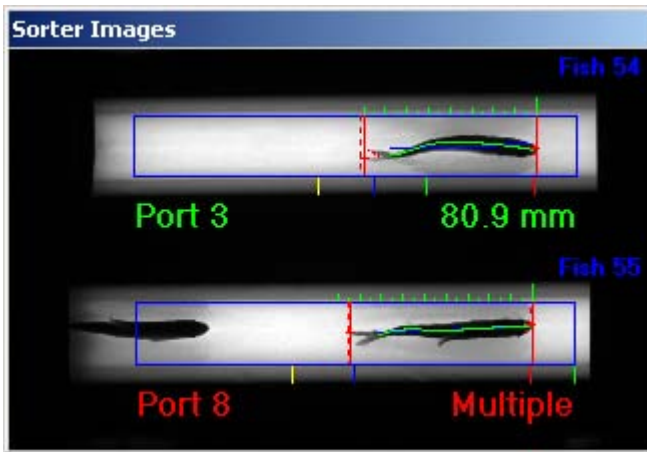

Figure 14: Multiple

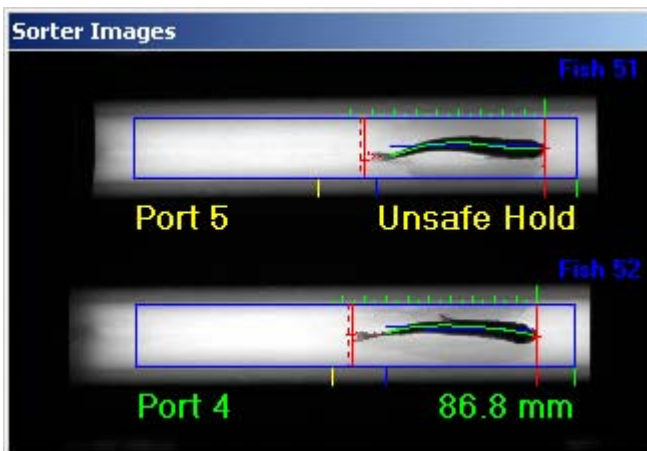

Figure 15: Unsafe Hold

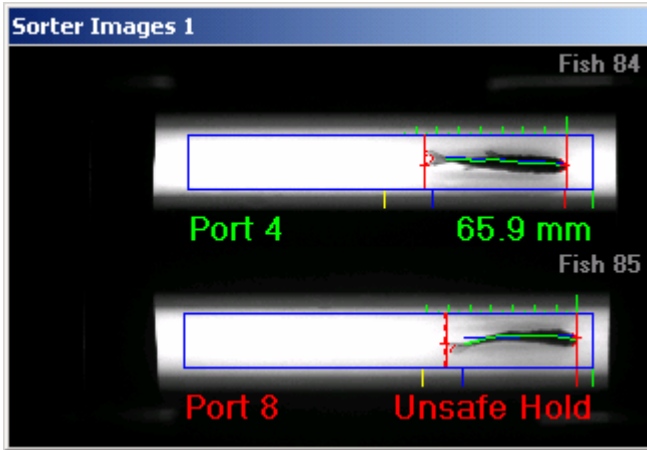
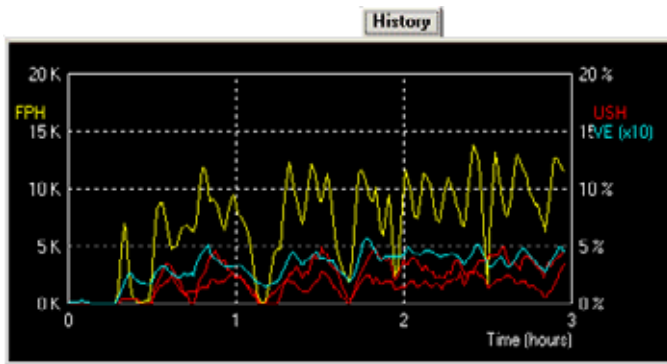

Figure 16: Rejected Unsafe Hold

★ History



The 'History' tab in the 'Sorter Data' window contains the throughput data for each channel graphed over time. Also shown on this graph are the unsafe holds for each channel and the density of the sorter VE. The Throughput History data can be reset by pressing the 'Reset History' button located on the main 'Sorter Data' window.

Shutdown:



The sorter software is shut down by pressing the 'Shut Down' button on the main sorter screen. The computer must be shutdown following the standard Microsoft shutdown procedures as follows:

1. Press the 'Start' button in the lower left of the screen.
2. Select 'Turn Off Computer'.
3. Accept the option to 'Turn Off' the computer.
4. Wait until the computer shuts down and the screen is white.
5. Finally, the system can be turned off with the green power switch.

AutoFish Sorter Components

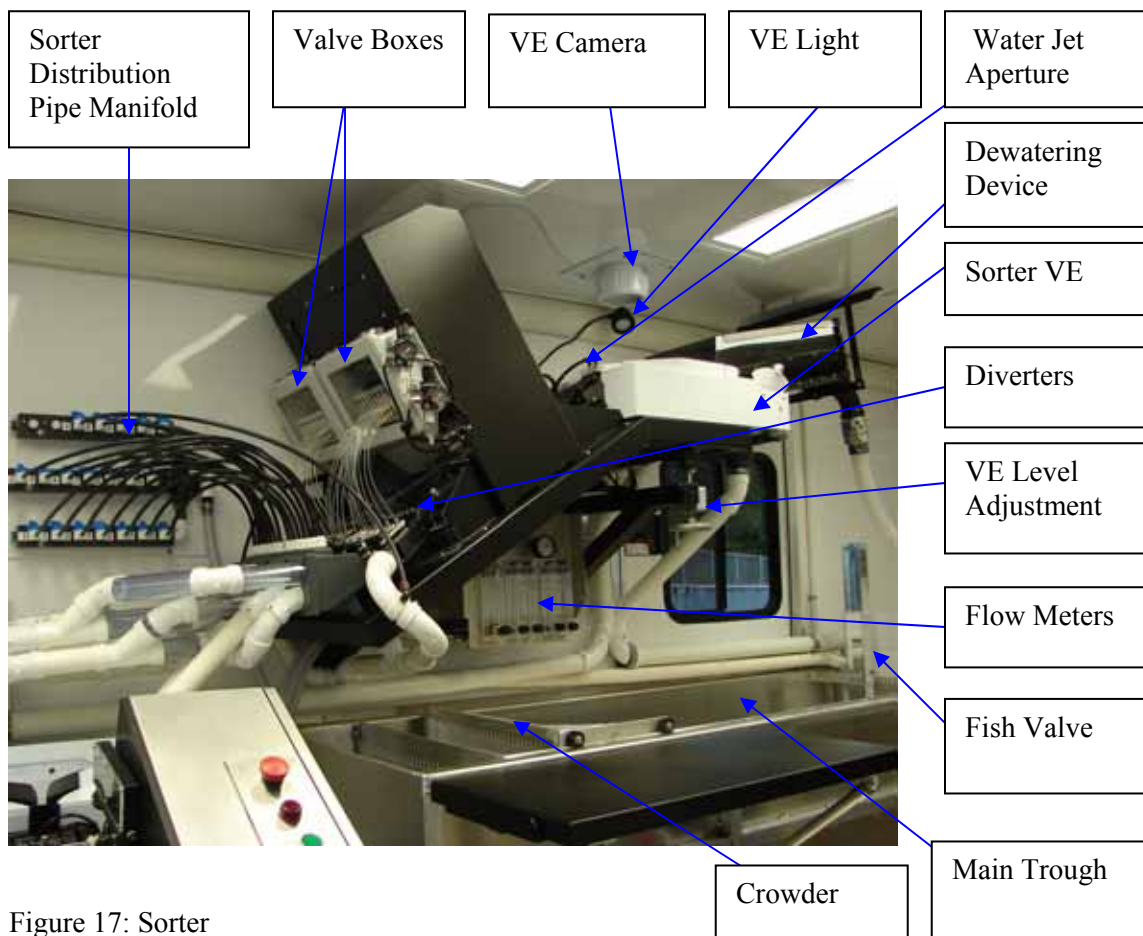

Figure 17: Sorter

Main Trough and Crowder:

The main trough, located in the front of the trailer (Figure 17), is the primary holding area for fish prior to being processed. The water intake for the trough is located at the front of the trough. The water flow is adjusted using the valve directly under the intake mounted below the trough. The water flows out of the trough through a 4 inch stand pipe located at the end of the trough. Inside the main trough is a mobile crowder that is used to push fish towards the fish valve.

Sorter Volitional Entry (VE):

The sorter VE is the receiving basin and staging area for fish (Figure 17) before entering the imaging area of the sorter. The sorter VE has one exit for each channel. The water is supplied to the sorter VE at the front and drains out the back of the VE to aid in head first orientation. The level of the sorter VE may be adjusted using the VE level adjustment wheels located below the VE on the sorter frame.

Fish Pump and Valve:

Fish transfer from the main trough to the sorter VE is accomplished using the fish valve in the trough and the fish pump mounted below the trough. All controls for the fish valve and pump are located in the sorter software and are explained in the previous sorter software section. The fish pump controller is located on the front wall of the trailer. The controller is used to adjust pump parameters and should not be used as an operator interface.

The fish valve is driven by an electric actuator. The actuator is attached to the valve shaft with a quick release pin. When the actuator moves into the open position, it lifts the valve shaft and the rubber valve upward so that fish can move into the fish pump. At any time, the valve release pin may be removed to stop the flow of fish to the fish pump. A valve position gauge is attached to the actuator to monitor the open and closed position of the valve and is measured in inches (Figure 18).

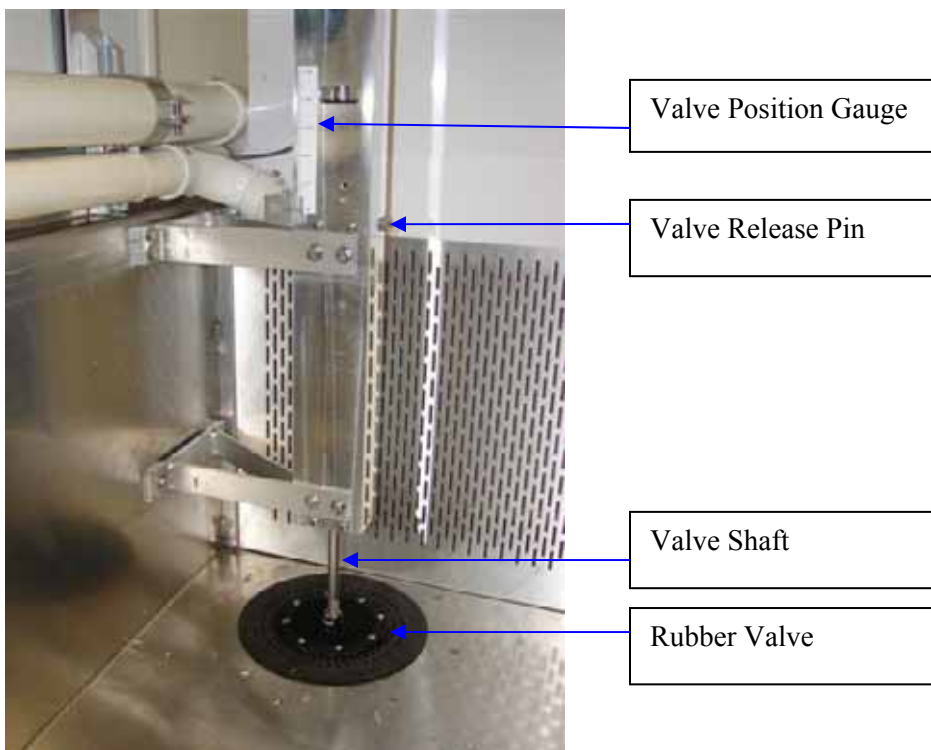

Figure 18: Fish Valve

The pump used to supply fish from the trough to the sorter VE is distributed by Matsusaka Ltd. Caution should be taken not to allow any foreign object to enter the pump. This may result in damage to the internal structure of the pump housing. If the pump fails, contact NMT for assistance.

The fish pump is driven by a variable speed electric motor. The fish pump motor and the fish pump housing interface using two pulleys and a belt. As the motor shaft rotates, the motion is translated to the pump through the belt, turning the one piece impeller in the fish pump housing. With the fish valve open and the impeller turning, the fish are drawn through the pump and forced out the fish transfer pipe, up over the de-watering device, and into the sorter VE. Mounted in the

fish transfer pipe flange is a pressure sensor (Figure 19). This pressure sensor measures the percentage of water flow and is utilized by the software to regulate the pump speed.

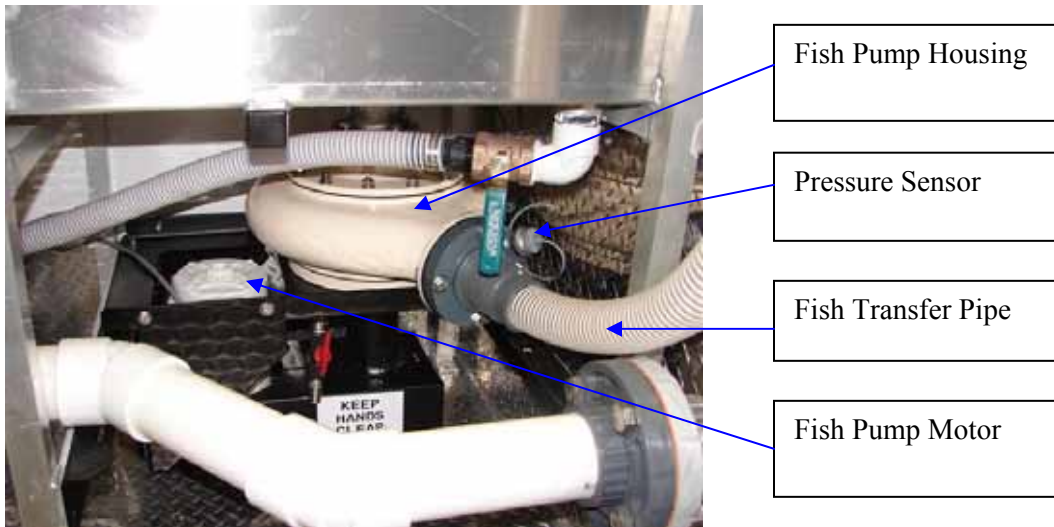

Figure 19: Fish Pump

VE Camera and Light:

As shown in Figure 17, a camera is mounted on the ceiling just above the sorter VE. This camera provides an image of the VE, so that the computer can determine the density of fish in the VE. To provide uniform lighting for the sorter VE image, a light is mounted adjacent to the camera. The power switch for this light is located on the front wall of the trailer.

Sorter Camera and Backlight Chute:

There are two main components of the sorter imaging system; the sorter camera and the backlight chute (Figure 20). The sorter camera images each fish so that it may be measured by the software. The backlight chute provides a channel for the fish to travel and a lighted back drop for imaging. The sorter camera is located in the black enclosure mounted over the backlight chutes. To access the camera, open the door at the front of the enclosure and remove the top to the camera housing. The sorter camera is positioned facing up. The image is directed down towards the backlight chutes via mirrors mounted in the top of the camera enclosure. Occasionally, these mirrors will become dirty or get water spots and will need to be cleaned.

There are two adjustments on the sorter camera, the F-stop adjustment and the focus (Figure 20). The F-stop adjusts the amount of light allowed into the lens of the camera. As the F-stop is opened, the image on the sorter software will lighten and as the F-stop is closed, the image will darken. If sorting is attempted with the F-stop too light or too dark, the imaging of the tail will be disrupted. The F-stop is adjusted by turning the top adjustment ring on the sorter camera lens. Once the adjustment is final, tighten the small set screw on the F-stop adjustment to prevent it from moving. It is recommended that after an adjustment to the F-stop that the background be calibrated as described in the sorter software section.

The focus adjustment on the sorter camera is located on the lens just below the F-stop adjustment (Figure 20). Focus adjustment must be done during the sorter calibration process explained in the sorter software section. With the calibration rod in the channel move the focus adjustment until the edges of the rod are sharp. Once the adjustment is final, tighten the small set screw on the focus adjustment to prevent it from moving. It is recommended that after a focus adjustment that the sorter be calibrated as described in the sorter software section.

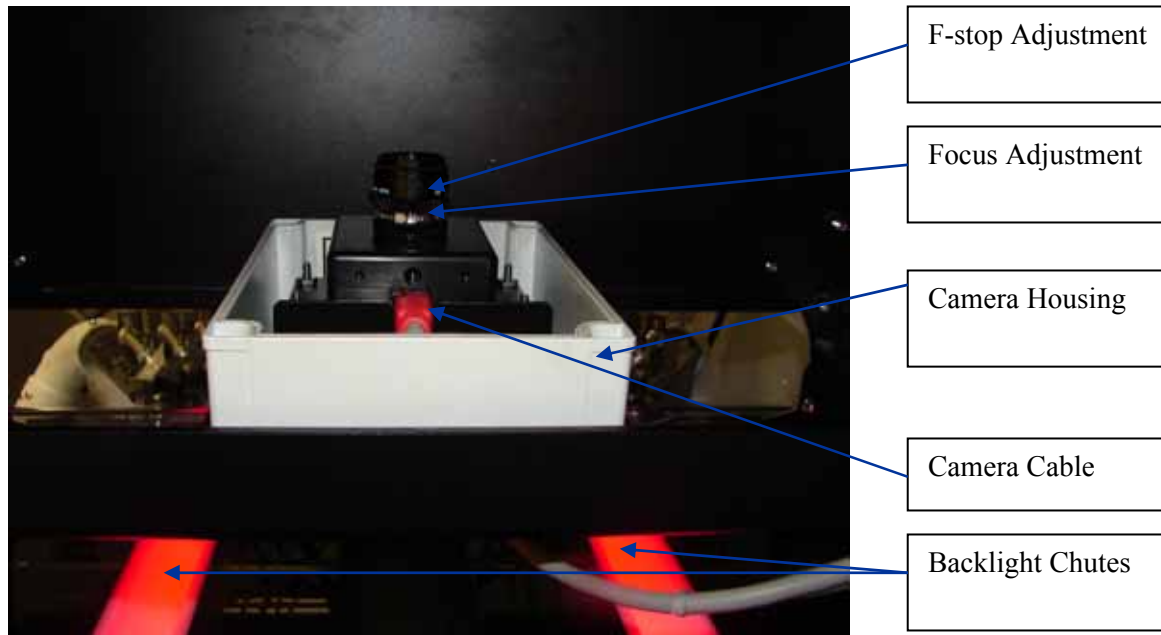

Figure 20: Sorter Camera

Backlight Chute Cover:

The backlight chute cover is located between the aperture and the imaging area of the backlight chute. Proper positioning of this cover is important in maintaining fish orientation through the imaging area. If fish are jumping in or near the imaging area, the cover may need to be adjusted to make the chute more comfortable.

Sorter Distribution Pipe Manifold:

The sorter distribution pipe manifolds contain an array of water valves that control the water to the sorter distribution pipes. All three manifolds are supplied water from the main water line. There is one manifold for each diverter. Each valve is labeled with the number that corresponds to the port number in which it supplies water to. The third manifold supplies water to the flopper stopper and the reject ports. Each distribution pipe has a valve for adjusting water flow. The water flow should be adjusted so that the fish travel naturally through the pipe to the VE. De-watering devices are placed on the end of each of the distribution pipes to ensure that excess water does not disrupt the flow of water in the VE.

Sorter Water Flow and Sorter Booster Pump:

Located just below the sorter VE is a row of water flow meters used to control the water to the sorter (Figure 21). The large flow meter mounted to the far left is used to control the water supply to the sorter VE. This water is supplied from the main water line. Under normal operation this flow meter should be set between 6 and 7 gpm. The amount of water going to the sorter VE can be adjusted by turning the black knob on the bottom of the meter until the desired water flow is attained.

The four smaller flow meters located to the right of the VE flow meter provide water to each channel of the sorter. These four flow meters are supplied water from the sorter booster pump located below the front trough. The pump is a Davey (model HS 12 40H1) and is rated at 12 gpm at 40 psi. The booster pump draws water from the sump area of the trough, boosts the pressure, and delivers it to the sorter. This ensures constant and reliable water flow to the critical areas. The booster pump pressure gauge is mounted just above the flow meters and should read between 50 and 60 psi while operating.

The main power switch for the sorter booster pump is located on the front wall of the trailer. The power for the sorter booster pump may be turned on once the front trough is full. In the event the booster pump is run without water and/or loses its prime it may be re-primed using the following procedure.

1. Turn off the power to the sorter booster pump.
2. Open the priming valve on top of the booster pump.
3. Ensure a solid flow of water from the priming valve.
4. Close the priming valve.
5. Turn on the power to the sorter booster pump.
6. If the pump does not turn on press the yellow re-start button located on the pump.

The sorter booster pump has a filter on the intake line should be cleaned periodically. If the booster pump pressure begins to drop much below 50 psi the filter may need to be cleaned. The filter may be cleaned using the following procedures.

1. Turn off the power to the sorter booster pump.
2. Close the valve located between the trough and the booster pump filter.
3. Un-screw the clear filter housing making sure not to misplace the large black O-ring.
4. Remove the filter and wash off any debris.
5. Re-install all pieces.
6. Open the valve located between the trough and the booster pump filter.
7. Turn on the power to the sorter booster pump.

The two flow meters located just to the right of the VE flow meter correspond to the water for channel 1. Channel 1 is the channel closest to the side-wall of the trailer. The first flow meter is the transition water flow which supplies water just past the aperture. The transition water flow is set dependent on fish size and behavior and is typically set between 1.0 and 3.0 gpm. The transition water is supplied by the sorter booster pump. The flow meter for the aperture jets is located just to the right of the transition flow meter. This flow meter measures the amount of water being released through the jets when the trigger sensor is actuated. Jet pressure aids in separation and is dependent on fish size and behavior and is typically operated between 0.5 and 2.0 gpm when actuated. The jet water is also supplied by the sorter booster pump. Located to the

right of the channel 1 flow meters are the transition and jet flow meters for channel 2. Channel 2 is the channel closest to the operator.

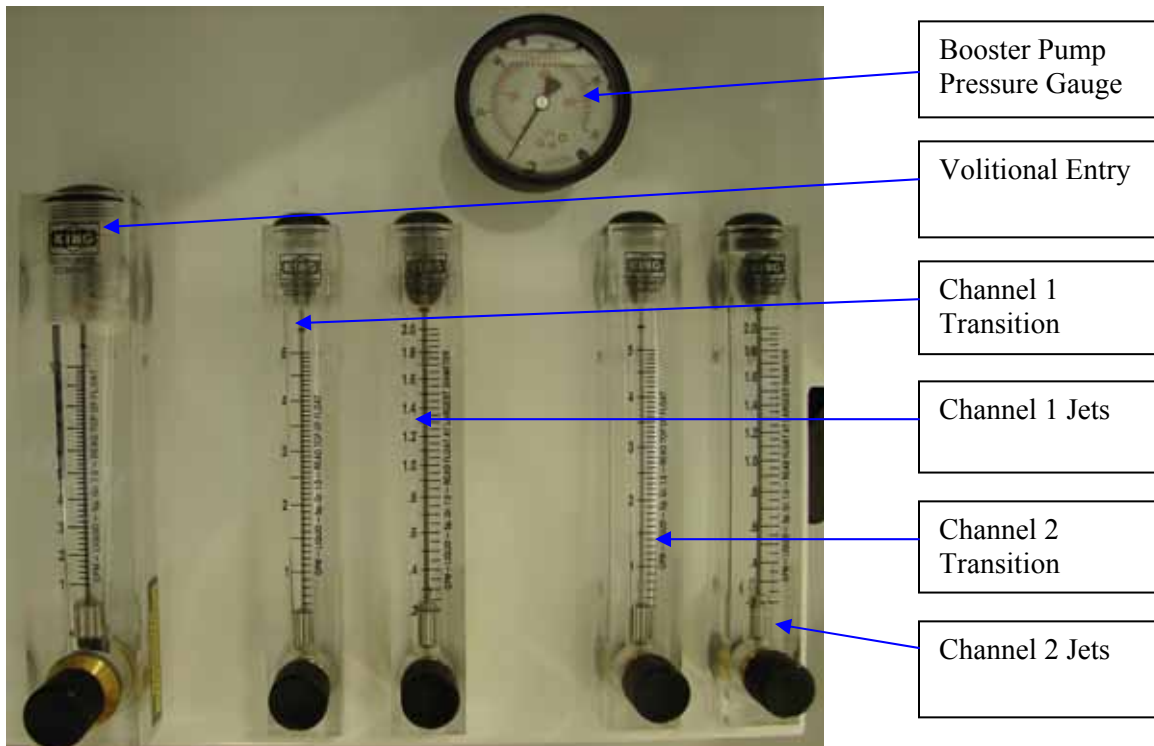

Figure 21: Sorter Water Flow Meters

Valve Boxes and Diverter Hardware:

The air cylinders, located on the diverter, drive the vanes that divert the fish to the designated port (Figure 22). The cylinders that actuate the diverter gates are pneumatically driven by means of a portable air compressor. The valve boxes (Figure 23) contain the electrical valves that control the air pressure to the air cylinders on the diverter. The computer communicates with the valves, which divert the air pressure to the corresponding air cylinder. A lighted connector mounted on top of the each air valve lights up when that particular valve is being utilized. Once a port has been selected, the valve routes the air to the cylinder and the cylinder extends. When the cylinder is extended, the wedge forces the vane to open the appropriate port.

It is important to monitor the condition of the air cylinders. If a cylinder begins to actuate slower than normal, it will need to be replaced immediately. Cylinder life can be prolonged by oiling them on a daily basis. A single drop of food grade air tool oil should be placed on each shaft and inside each air fitting.

To replace an air cylinder, disconnect the air hoses and unscrew the nylon lock nut that holds the plate on the cylinder mount. Remove the shaft that holds the cylinder in place and replace the worn cylinder with a new one. When replacing the wedge on the new cylinder, thread the wedge locknut onto the cylinder shaft followed by the wedge. With the wedge locknut tight and the cylinder shaft fully retracted, there should be a 1mm gap between the locknut and the top of the air cylinder.

For each valve box there is a corresponding air regulator mounted on the outside of the channel 2 valve box. The air pressure coming from the compressor to the valve box is adjustable using the knob located on the top of the regulator and should be set at 50 psi. A water trap is located below each regulator to collect any water that may be in the air line. The water may be released from the trap by pressing the small release valve on the bottom.

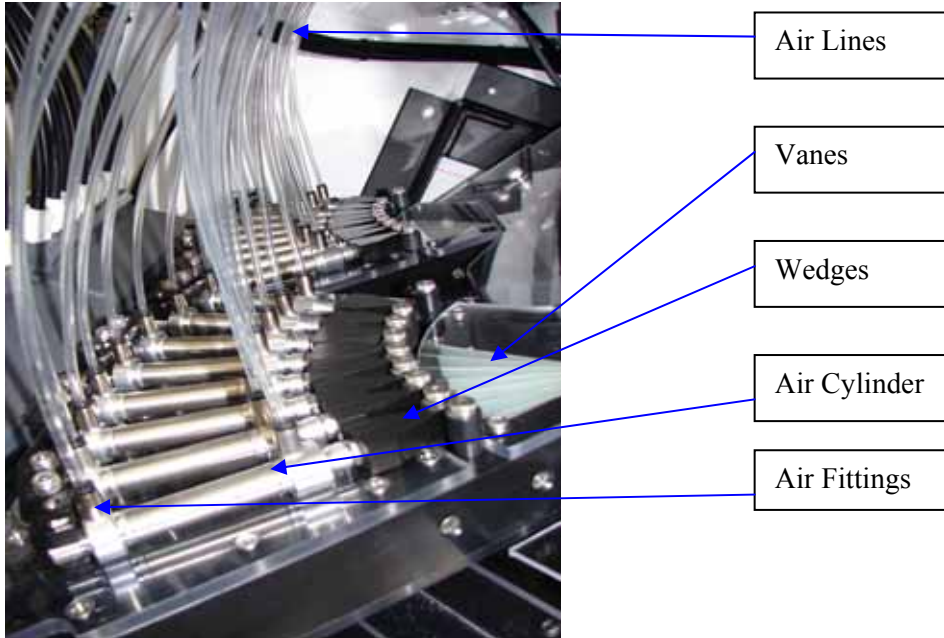

Figure 22: Diverter Hardware

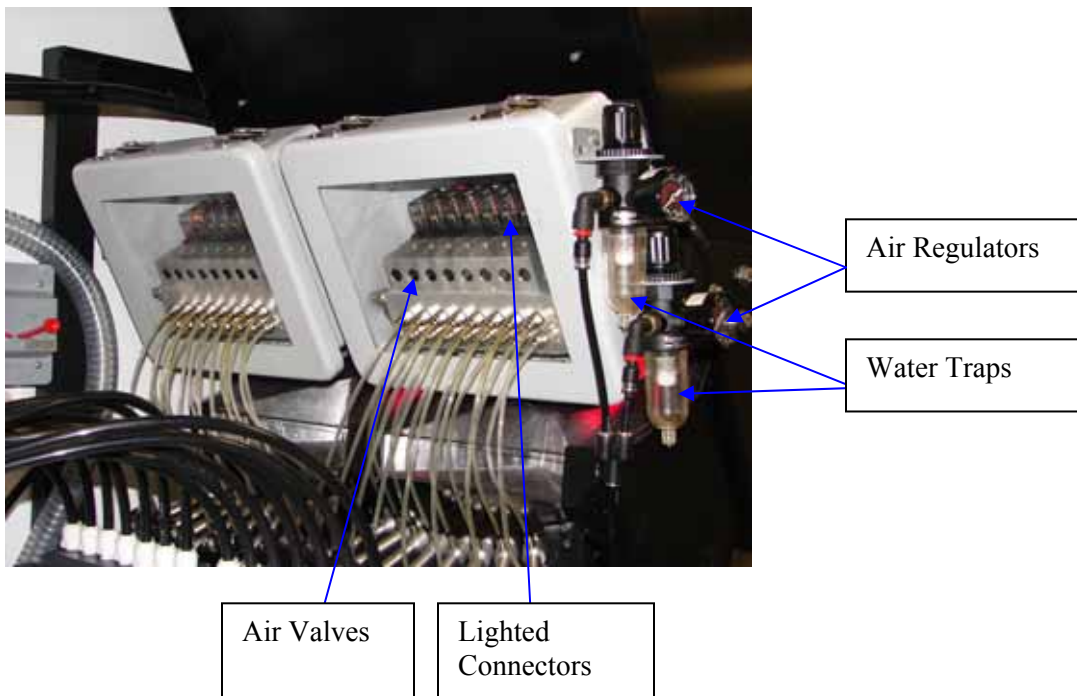

Figure 23: Valve Boxes

Wire and Water Jet Aperture:

In order to maintain a balance of separation and throughput, the aperture, at the exits of the VE, contain several adjustable components. The set of wires which make up the aperture are fully adjustable. On the inside wall of the VE where the wires are attached, there is a 9/64 allen head screw as shown in Figure 24. Rotating this screw clockwise will move the set of wires closer together for sorting smaller fish. Rotating this screw counter-clockwise will move the set of wires further apart for sorting larger fish.

Located between the set of wires is a roof which is also adjustable. Caution must be taken not to damage the wires when adjusting the roof beyond the top of the wires. The roof can be moved by loosening the thumbscrew and making the desired adjustments. Located just outside the adjustable roof is a stop gate that can be closed to stop fish throughput immediately.

If the wires are damaged, the wire aperture gauge is supplied to re-bend or adjust slightly damaged wires. This will help create the correct angle of the bend and the correct spacing between the wires.

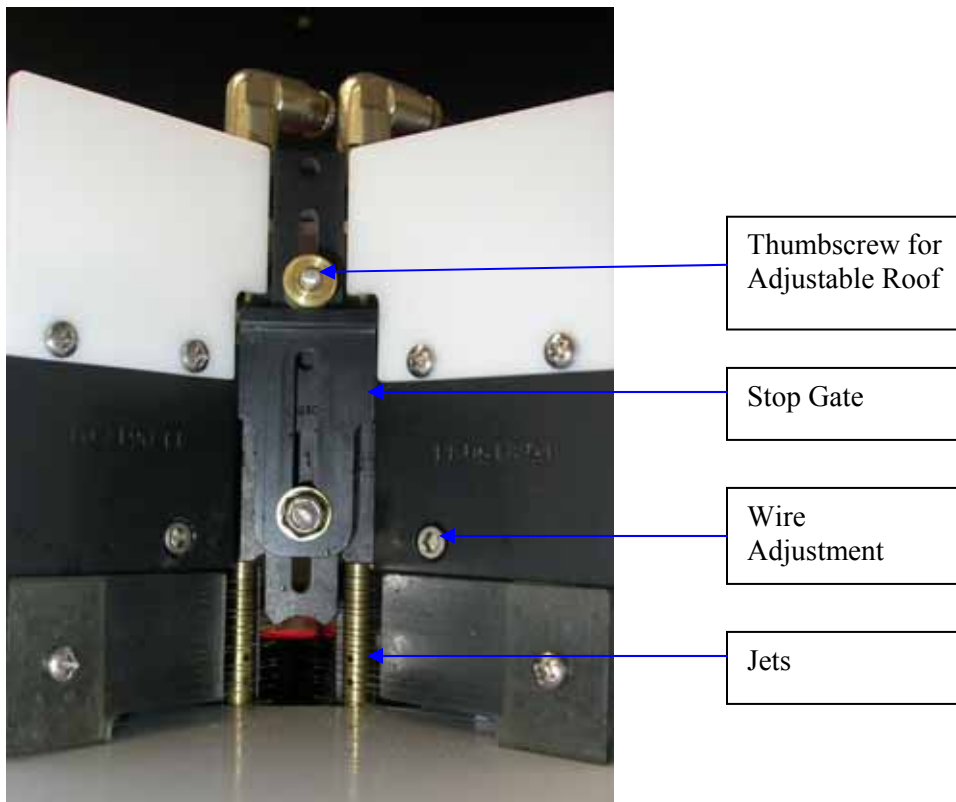

Figure 24: Sorter Wire Aperture

The sorter aperture also consists of water jets that aid in fish separation. There are two sets of water jets; the two-hole and the three-hole jets. The two-hole jet tubes are typically used for smaller fish and the three-hole jets are used for larger fish. To remove the water jets, remove the water line from the top of the jets, remove the jet angle gauge, loosen the jet angle adjustment thumbscrews, and pull the water jets straight out of the aperture.

The angle in which the water jets actuate into the VE is adjustable (Figure 25). When processing smaller fish, the angle of the jets should be approximately 30-degrees and as the fish get larger, the angle of the jets will decrease. To change the angle of the jets loosen the two jet angle adjustment thumbscrews. Rotate the jet until the jet angle adjustment indicator aligns with the desired angle on the jet angle adjustment gauge. After the adjustments are final tighten the jet angle adjustment thumbscrews to hold the jets in position.

There are three IR sensors just downstream of the sorter aperture. As soon as the selected sensor is blocked, the water jets are triggered. When the sensor detects light (after the fish has passed), the jets turn off allowing another fish to enter the aperture. This adjustment helps to create adequate separation between fish. Trigger sensor #1 is the most upstream sensor and is used for smaller fish. Trigger sensor #2 and #3 are respectively downstream and are used for larger fish. The adjustment for the trigger sensor is found in the Sorter Setup window of the sorter software.

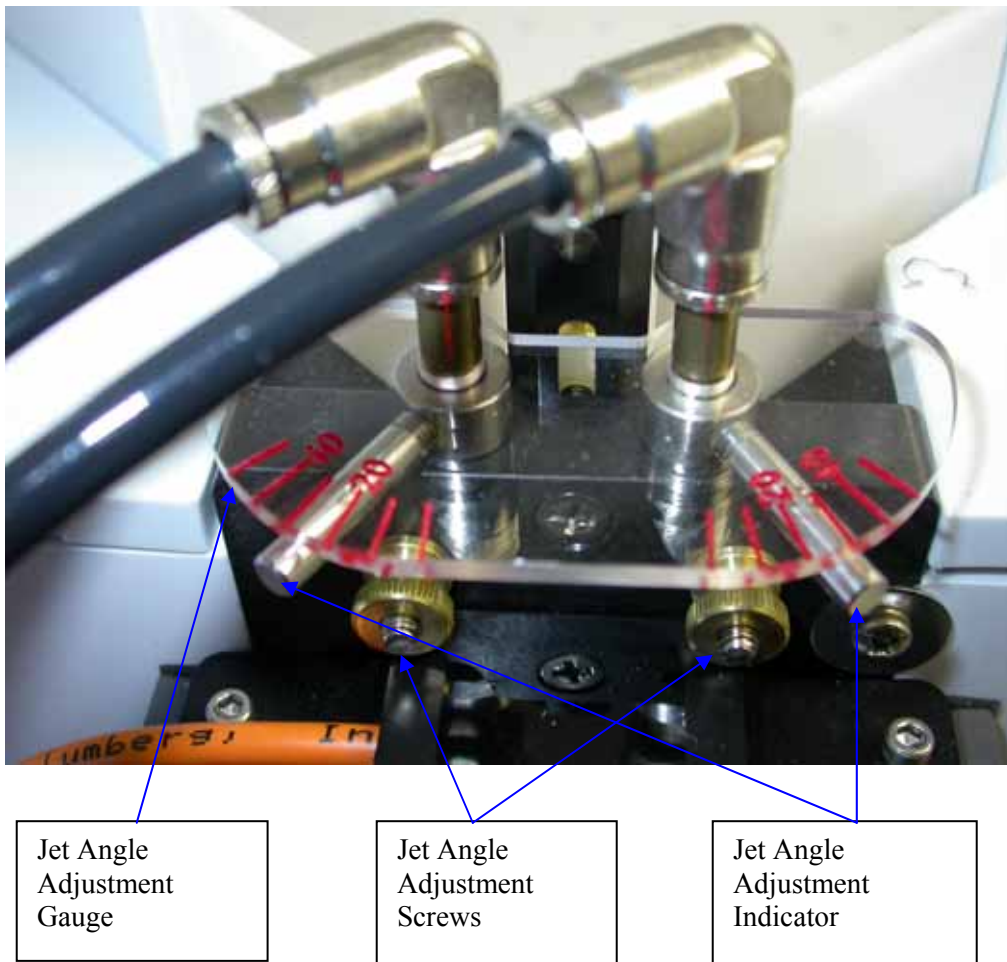

Figure 25: Sorter Water Jet Aperture

AutoFish Line Software Operation

Software Overview:

The marking and tagging lines are controlled by software through a conventional PC using Windows XP operating system. Two separate programs; the supervisor and the line controller program are used in conjunction to perform all line operations. These programs are started automatically when the system is turned on, but must be shut down following the shutdown procedures described in the following section.

The supervisor program defines default settings for each of the fish sizes, totals batch information, and opens and closes the individual line controllers.

A separate and individual copy of the line controller program directly controls each line. The line controller software defines the settings for each line, sends basic commands to the line, provides image processing, and keeps track of batch information.

Startup:

Using the green power switch labeled 'Lines' on the front wall of the trailer, turn the power on to the marking and tagging computer. When the computer is turned on, the supervisor and all the necessary copies of the line controller software will automatically start. Each line controller may be individually started by double clicking the corresponding icon on the desktop.

Supervisor:

The supervisor's batch information, as shown in Figure 26, displays the sum of the batch statistics of the lines. The title bar on the Supervisor displays the current version of software. The batch number, time the batch was started, run hours, and how many fish per hour have been processed during that time are also displayed in this window. The run hours are equal to the longest running line in the trailer. Located to the right of the batch information are the four supervisor control buttons.

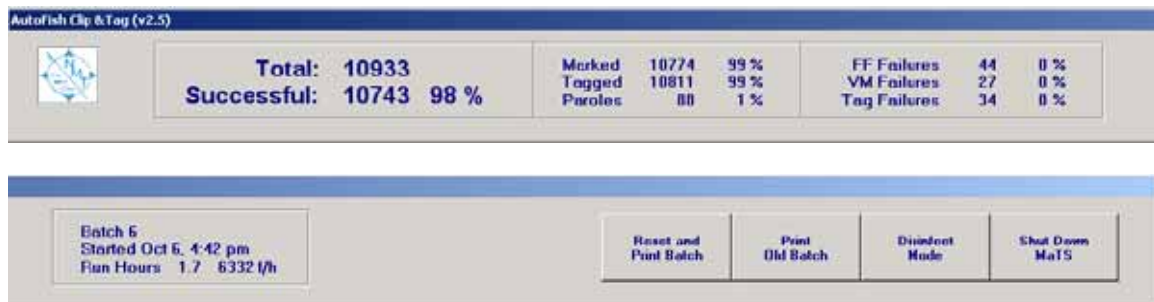

Figure 26: Supervisor Window

★Print and Reset Batch



The current batch may be printed at any time using the 'Reset and Print Batch' button. Since this will immediately reset all batch information, a verification window will be displayed as shown in Figure 27.

★Print Old Batch



An old batch can be reprinted at any time using the 'Print Old Batch' button. The operator may scroll through the previous batches using the left and right arrow keys as shown in Figure 28 and choose 'Print' once the appropriate batch is located.

★Disinfect Mode



The 'Disinfect Mode' is used for disinfecting and rinsing. When the software is placed in 'Disinfect Mode', the fin washers and the fish ejection solenoids open to allow a continuous flow of water for rinsing or disinfection. Touching this button again will exit the disinfection mode and close the line solenoids.

★Shut Down MaTS



The supervisor and all of the corresponding line controllers are shutdown by pressing the 'Shut Down' button on the supervisor. The computer must be shutdown following the standard Microsoft shutdown procedures as follows:

1. Press the 'Start' button in the lower left of the screen.
2. Select 'Turn Off Computer'.
3. Accept the option to 'Turn Off' the computer.
4. Wait until the computer shuts down and the screen is white.
5. Finally, the system can be turned off using the green power switch.

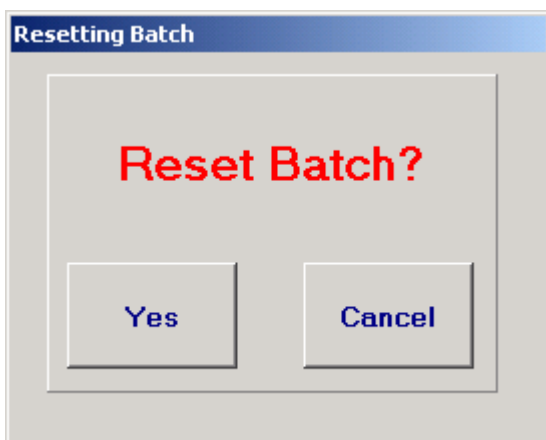

Figure 27: Reset Batch Verification

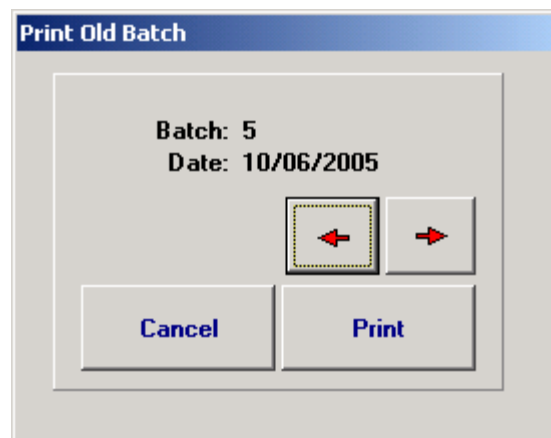

Figure 28: Print Old Batch Window

Line Controller:

The top of the line controller displays the line status, fish size, and the function currently being performed. Below the line status is the image window and image control buttons. Viewing and controlling images are primarily for supervisory monitoring and troubleshooting. The lower area consists of multiple tab controls, which allow the user to view and modify various types of information. The bottom of the line controller consists of a row of buttons used to control the line status.

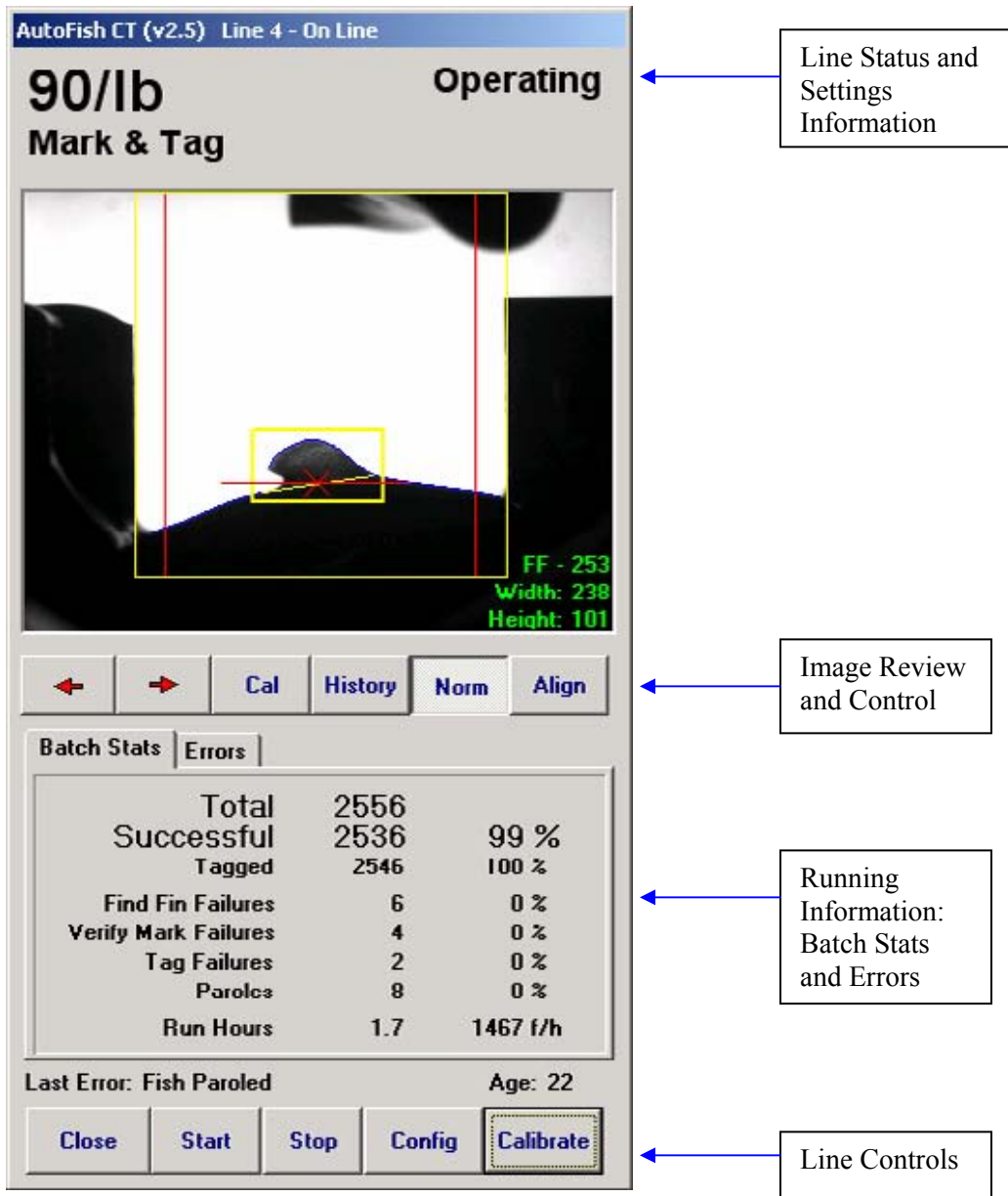

Figure 29: Line Controller Main Window

★Line Status and Settings Information



The title bar on each line controller displays the line number and the

current version of software. The title bar also displays an indicator of line status which shows whether the line is communicating (On Line) or not (Off Line). An Off Line message may either indicate that the line is not receiving power or a potential communication error has occurred between the line and the computer.

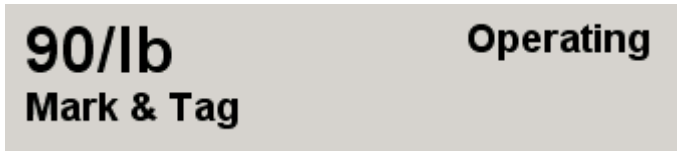

Just below the title bar, the fish size and the current function being performed are displayed. The function options are: Mark Only, Tag Only, and Mark and Tag. To the right of the

fish size, the current line status is displayed. The line status may display the following:

1. Off Line: Line is not communicating.
2. Needs Calibration: Line needs to be calibrated.
3. Recalibrating: Line is currently recalibrating.
4. Stopped: Line is stopped.
5. Operating: Line is operating.

Just below the line status indicator is the Simulation display, which is shown when the line is set up to operate in simulation mode. If this indicator is not visible, the line is in normal (fish processing) mode.

Just below the Simulation indicator is a No Video indicator, which indicates that the computer is not receiving a video signal from the line camera. This situation can occur if either the line is not receiving power or if there is a problem with the camera, cables, or the computer.

★Image Review and Control

There are four image display control buttons. Only one of these options may be selected at any given time. There are also two arrow buttons, which only have application during several the 'Cal' and 'History' image display modes. The four image display control buttons are: 'Cal', 'History', 'Norm', and 'Align'. These buttons control only the image display and the line will continue processing fish regardless of what image display is selected.



The 'Norm' display is used as the standard operating mode. In the normal mode, the display always shows the most current image of interest and that image remains visible until the next fish is processed.



The 'Align' image display shows a live image and is used to align the camera to the clamp window.



The 'Cal' image display allows the user to view the two latest calibration images. The left and right arrows may be used to toggle between the two images at any time.



The 'History' image display shows pairs of fish images for the last 100 fish processed. The user may view the images by using the left and right arrow buttons.

For distant viewing, the user can click on the image to view an enlarged version. When operating in this mode, the user may view the last calibration images, the clip history or view a live image. The Zoom button on the handheld controller may also be used to enlarge the image for any line. To hide the large image, click on the image or press Zoom again on the handheld controller.

★ Batch Stats and Errors

The lower center section of the line controller main window (Figure 29) contains a tab control, which displays various types of information as the system is operating. These tabs include ‘Batch Stats’ and ‘Errors’.

Batch Stats		
Total	2556	
Successful	2536	99 %
Tagged	2546	100 %
Find Fin Failures	6	0 %
Verify Mark Failures	4	0 %
Tag Failures	2	0 %
Paroles	8	0 %
Run Hours	1.7	1467 f/h

The ‘Batch Stats’ page displays individual line performance. The items on the batch page include; Total, Successful, Tagged, Find Fin Failures, Verify Mark Failures, Tag Failures, Paroles, Run Hours, and throughput in fish per hour. A percentage is also attached to each of the success and failure modes.

1. Total: The total number of fish released from the lower gate. Fish that are manually released above the lower gate are not counted in the total.
2. Successful: The number of fish successfully processed.
3. Tagged: The number of fish that have received a coded wire tag. In Mark & Tag mode, tagging is attempted even if the fin is not located.
4. Find Fin Failures: The number of fish whose adipose fin could not be located.
5. Verify Mark Failures: The number of fish that the line attempted to adipose clip, but the fin was not successfully removed.
6. Tag Failures: The number of fish the MKIV attempted to tag, but no tag was detected by the Quality Control Device.
7. Paroles: The number of fish that were released from the system as they did not reach the nose sensor in time.
8. Run Hours: The total number of hours the Line has been in ‘Operating’ mode since the batch was reset. The throughput value is the number of successfully processed fish per hour within this time period.

Errors	
41	Fish Stuck at Upper Gate
0	Fish Too Short
1	Insufficient Fin Removal
2	Insufficient Fin Removal
0	Fish Too Short
0	Fish Moved
0	Fish Moved
0	Fish Moved
2	Insufficient Fin Removal

The 'Errors' page displays all errors that occur during processing. Each error has an age in number of fish processed between the previous and the current error. Not all of the errors reported on this page result in an unsuccessful fish. A description of these errors is detailed in the Marking and Tagging Errors section. The last error is always visible just below the Errors tab on the line controller main window. Also displayed, to the right of

the last error, is the age of that particular error in number of fish.

★Line Controls

Located at the bottom of the Line Controller (Figure 29) are the buttons that are used to control the actions of the line. These include: 'Close', 'Start', 'Stop', 'Config', and 'Calibrate'.



The 'Close' button is used to close individual line controllers. To re-open the line controller, double click on the corresponding icon on the desktop.



The 'Start' and 'Stop' buttons start and stop the line while processing fish. The line must be calibrated in order for these controls to function.

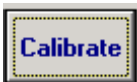

The 'Calibrate' button starts the calibration process. Calibration is discussed in the Calibration section below.



The 'Config' button opens up a window in which the line configuration is defined. The options are described in the next section.



The Configure window has three pages of options accessible via page tabs. These tabs include: 'Basics', 'Override', and 'Special'.

All adjustments are made by selecting an option to change and using the adjacent arrow keys to adjust that selection. New selections become active when either the 'Accept' button or the 'Accept & Close' buttons are pressed. Once the 'Accept' button is touched, the selection immediately becomes active, and the Configure window remains open. The 'Accept & Close' button recognizes any changes and closes the Configure window. The 'Cancel' button closes the Configure window without saving any current changes.

★ Basic Settings

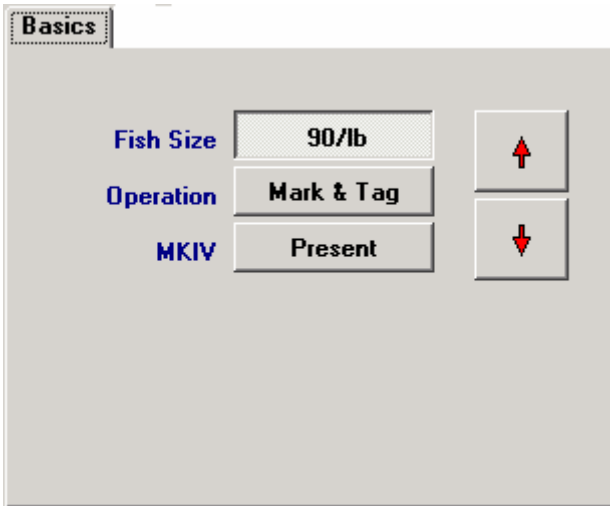

The ‘Basic’ settings tab consists of the main settings for the line which include: Fish Size, Operation, and MKIV. The settings on this page must be adjusted prior to calibration of the line.

The Fish Size setting defines motor positions, calibration factors, and sensor choices for a given size of fish. The fish sizes available on this page match the sorter default fish sizes and the two must be set to match. The fish size must also be properly set to match the clamps installed on the marking and tagging line or the line will not calibrate.

The Operation setting defines the function to be performed which includes; Mark Only, Tag Only, or Mark & Tag.

The MKIV setting allows the lines to be operated without the MKIV when in Mark Only mode. The QCD, which is normally controlled by the MKIV, is still required. The QCD can be controlled directly by the line by selecting MKIV ‘Absent’ on this screen, connecting the QCD directly to the line, and utilizing the MKIV head mold simulator as described in the MKIV section .

★ Override Settings

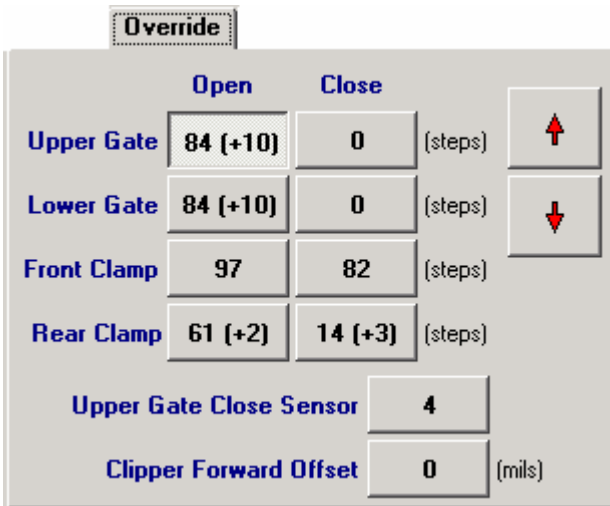

The second tab in the Configure window is the ‘Override’ tab. The ‘Override’ tab allows the user to adjust individual motor and sensor settings for fine-tuning. When a fish size is selected, the default settings are displayed on the Override tab. The user may change any of the default settings as required to improve the performance of each individual line by using the up and down arrows. When a setting is changed, the delta (+ or -) from the default setting is displayed. The line controller saves all settings when shutdown and will startup again with the same settings. Once the ‘Accept’ or the ‘Accept and Close’ buttons are touched, the changes are immediately effective on the line.

The Override settings can also be changed from the hand held controller and will be immediately updated in the software. This process is described in greater detail in the handheld controller section.

The upper gate, lower gate, front clamp, and rear clamp are all adjusted similarly. There is a setting (in motor steps from the home position) for the open and the close position for each of these mechanisms. In each of these cases, increasing the number will further open the mechanism. The gates move 5° for each 10 motor steps. The front and rear clamps move 0.1” for each 10 motor steps.

The Upper Gate Close Sensor defines which sensor will be used to trigger the upper gate to close. The best sensor to use for this setting is fish length dependent as the upper gate needs to strip off the following fish. Sensor 1 is the first sensor past the upper gate and sensor 8 is the last one that can be used for this purpose.

The Clipper Forward Offset defines how the blade is to be positioned in reference to the center of the adipose fin. With this setting at 0, the center of the blade will be directed to the center of the adipose fin. Increasing this value will move the cutter forward and decreasing this value will move the cutter rearward. The effect of changes made to this setting can be seen in the Find Fin Images. Both the position of the fin’s leading edge and the horizontal position of the blade are shown in these images and will be described in detail in the following sections.

★Special Settings

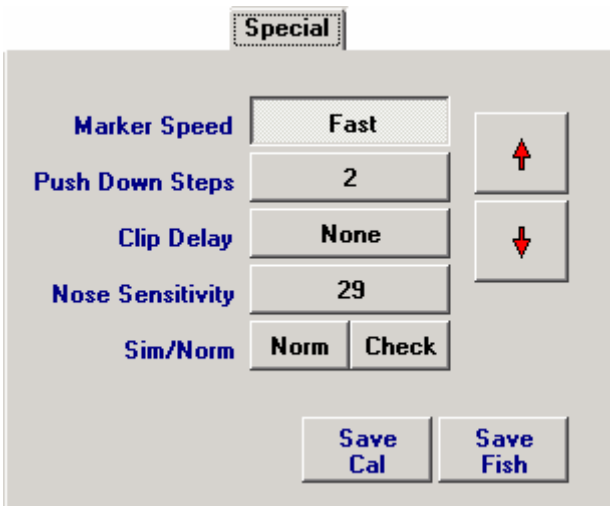

The third and final tab in the Configure window is the ‘Special’ tab. The ‘Special’ tab contains settings useful for troubleshooting and line-specific settings. The contents of the ‘Special’ page are: Marker Speed, Push Down Steps, Clip Delay, Trapdoor Delay, Nose Sensitivity, and Sim/Norm.

The Marker Speed and Clip Delay options allow the user to slow down the marker mechanism for troubleshooting purposes. The Marker Speed can be used to slow down the X and Y movements of the marker to watch for mechanical conflicts and other clipping issues. When the Clip

Delay button is engaged, the marker will move into position and the clipper will pause for one second prior to clipping. During normal operation mode, the marker operates in fast speed with no clip delay.

The Push Down Steps setting defines the number of motor steps the marker will move toward the fish after arriving at the designated fin position. This setting creates spring-generated pressure between the clipper and the fish.

The Nose Sensitivity sets the threshold at which the nose sensor triggers. This value may be adjusted between 1 and 50. If this value is too high (high sensitivity), the nose sensor may trigger before the fish is in place. If this value is set too low (low sensitivity), the fish may not block enough light to trigger the sensor.

The Sim/Norm setting is primarily used for troubleshooting and operational checks. Simulation mode operates all the mechanisms, but does not use the sensors. Fish must not be allowed into the line while being operated in simulation mode.

Operating the line in Simulation demonstrates the accuracy of the calibration of the marker and imaging system. This accuracy can be tested only when the second setting of the Sim/Norm options is set to Check. When properly calibrated in Simulation mode, the marker will alternate between the extremes of available travel within the adipose window region. The marker should travel extremely close to each edge of the window with out hitting the clamp edges. When the second setting of the Sim/Norm options is set to Burn-In, the marker does not travel close to the edges. Burn-In is typically only used for factory testing. The Check and Burn-In options are only available during Simulation mode.

Image processing:

The image processing for each line is used to calibrate the marker, find the adipose fin of each fish, and to direct the marker to the designated fin position. The following sections will describe the process of aligning the camera and interpreting the images involved with these processes.

★Aligning the Camera for Calibration

Once all of the settings described in the previous sections have been confirmed, the camera must be properly aligned with the clamp window for adipose clipping.

1. Make sure the camera assembly is seated properly in the mount.
2. Press the 'Align' button, which provides a live image along with alignment guides.
3. Adjust the focus to the far setting, and the F-stop should be set to provide maximum contrast on the computer screen (image appearance on the TV monitor is irrelevant).

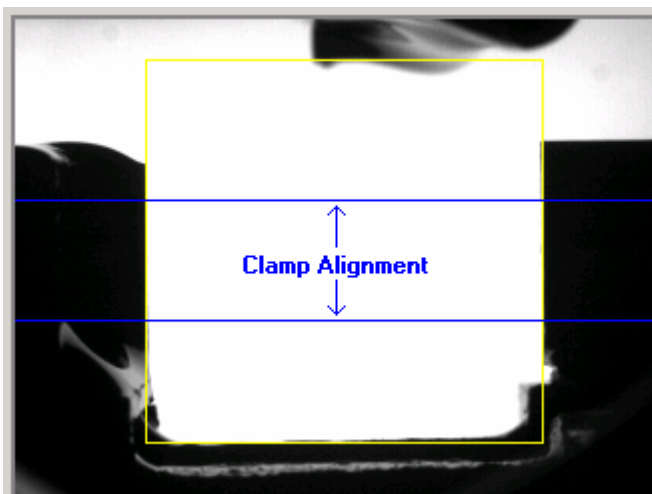

Once the software is in Align mode, the camera must be adjusted left or right so that the clamp window, designated by the yellow lines, is centered within the image. The exception to this rule is the 200/# clamps. The right edge of the clamp window may not be visible because it extends beyond the visible extent of the backlight. In this case, slide the camera downstream until the edge of the clamp window can be distinguished from the edge of the backlight. It is important to verify that the edge of the fish adapter plate is used to determine the extent of the

clamp window and not the edge of the backlight. Second, adjust the camera vertically. The camera is adjustable vertically by loosening the four screws around the camera and sliding the entire vision subsystem up or down, then re-tightening the screws. The blue lines define the vertical clamp alignment area, where the vertical clamp walls should be placed. The top of the clamp walls should be just above the upper blue line and the bottom of the clamp window should be visible in the bottom of the image.

★ Calibration Images

The line must be calibrated prior to operation. To calibrate the line push the 'Calibrate' button on the lower right hand side of the line controller or the 'Cal' button on the handheld. The green button on the line itself also serves as a calibration button. The imaging system will always be calibrated during the first calibration of the day.

Once calibration has been initiated, the system will home all the motors on the line and calibrate the marker and vision system. Errors may occur during the marker and vision system calibration and will require interpretation of the images. There are two images captured during calibration; the clamp window and the marker image.

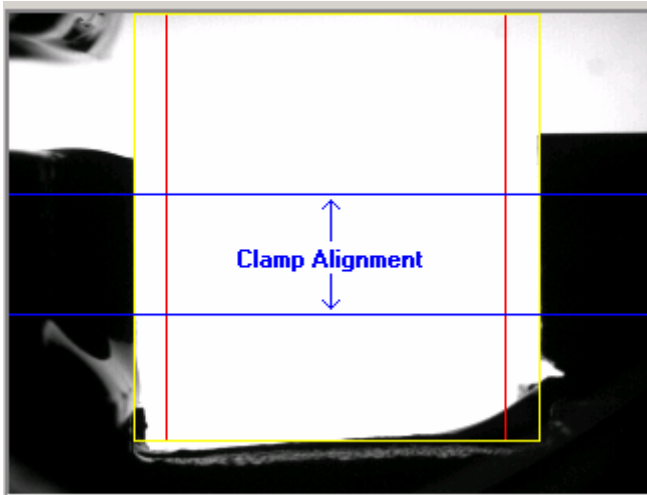

The first image taken is a picture of the clamp window. This picture is used for two things. The vision system locates the edges of the clamp window to define the limitations of the clipping mechanism. Next, the vision system compares these edges with the known dimensions of the installed clamps to determine if the two match. If the two do not match, the system will generate an error stating that the configuration does not match the clamp image. This usually indicates that the camera is not properly aligned. There are three things to look for on the clamp window

calibration image:

1. The red lines indicate the blade reach area showing how close the clipper block can travel to the edges of the clamp window.
2. Ensure that the yellow lines, which define the edges of the clamp window, are located at the edges of the clamp window.
3. Ensure that the area between the blue lines actually contains true clamp area.

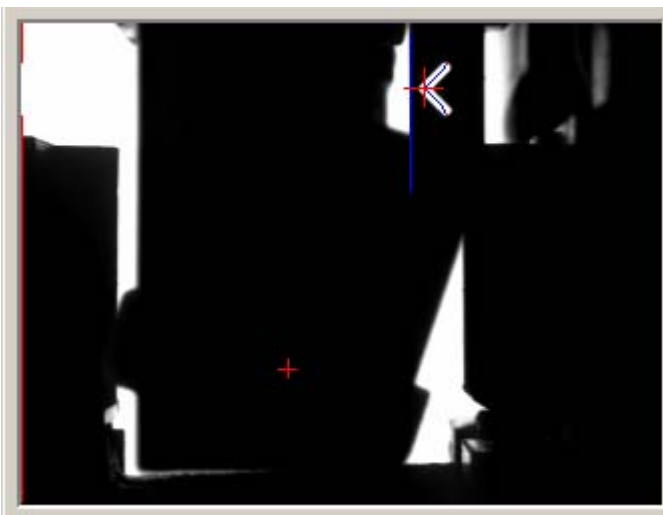

After the clamp window image is taken, the marker is directed into the clamp window and a second calibration image is taken. There are several reference points that the computer utilizes to determine the position of the marker from the camera's point of view. Because of the ease of recognition and the known relationship to the marker, the chevron within the fiducial is used to determine this position.

First the computer searches for the left edge of the fiducial. Once this edge is located, it is marked with a vertical

blue line. Next, the computer searches to the right of the blue line for the chevron. This is accomplished by searching for two white strips positioned at a 45° angle. The position in which these strips cross is determined to be the chevron and marked with a large red cross. The center of the marker is a known distance from this reference point and is marked with a small red cross.

If part of the chevron is not visible, calibration may fail. Any strip that is found, but is not part of a 45° section, is colored red. Any strip that is part of a 45° section is colored blue. If there are any blue pixels outside the chevron, the image may contain an anomaly with a white stripe at 45°. If there are expected colored pixels missing within the chevron, the image may be out of focus. If calibration is not successful, inspect the calibration images to determine where the problem lies and re-calibrate. If there are water drops on the fiducial, remove the water drops and re-calibrate.

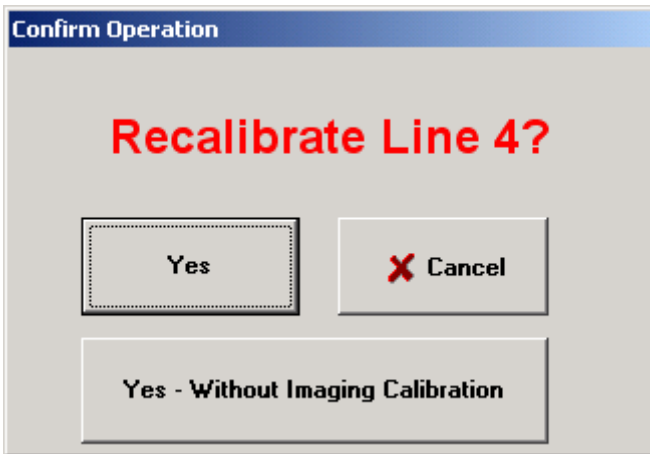

The operator should calibrate the imaging system anytime changes are made to the camera or the clipper mechanism. If the line has already been calibrated, but requires recalibration, the line controller or the handheld must be used as the green button will only start and stop the line. In this case, the computer will prompt the operator with a window offering a choice to re-calibrate with or without imaging. If the operator chooses to calibrate without imaging, the system will again only calibrate the stepper motors. Choosing

to calibrate with imaging will calibrate all of the stepper motors as well as the vision system.

★Find Fin Image

When marking fish, the vision system displays images utilized by line controller. There are two images used for this purpose. The first one locates the adipose fin and directs the marker to the appropriate position for clipping and the other image is used to verify that the fin was properly removed.

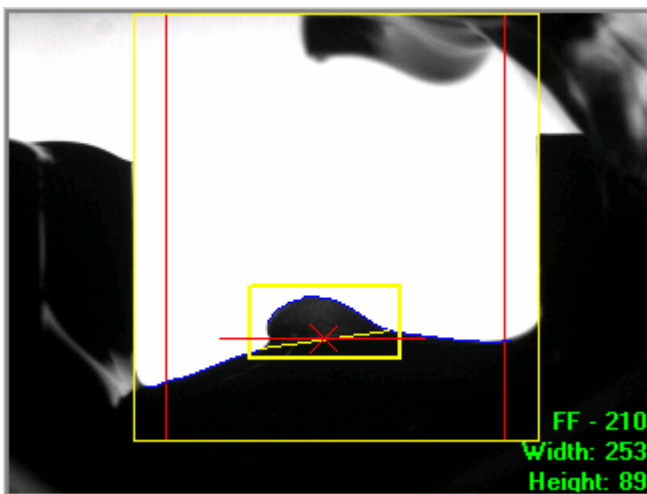

The first image displayed for each fish is the Find Fin Image. This image is used to determine the location of the adipose fin and the correct position to send the marker in order to remove the fin. The vision system displays the results of its attempt to locate the fin.

During the Find Fin process the edge of the fish back is traced in dark blue. A mathematical equation is used to locate the fin along the blue line. Once found, the fin area is shown within a yellow box. Inside the yellow box, a straight yellow line runs from the leading edge

of the fin to the trailing edge of the fin. Above this line is the fin area, which is to be removed.

In addition to the Find Fin information, blade positioning information is also displayed. As in the calibration image, the extents of the blade movement are shown in red. The size and position of the center of the blade are also shown in red. The position of the center of the blade is marked with a red X. When the fin is close to the edge of the clamp window, the marker movement is limited. This is shown by the red line of the blade touching the red line of the blade extents. An error is generated when this happens, but the fin is likely to be sufficiently removed.

In the lower right corner of the Find Fin image, the fish number and the resulting fin width and height are shown in thousands of an inch.

★ Verify Mark Image

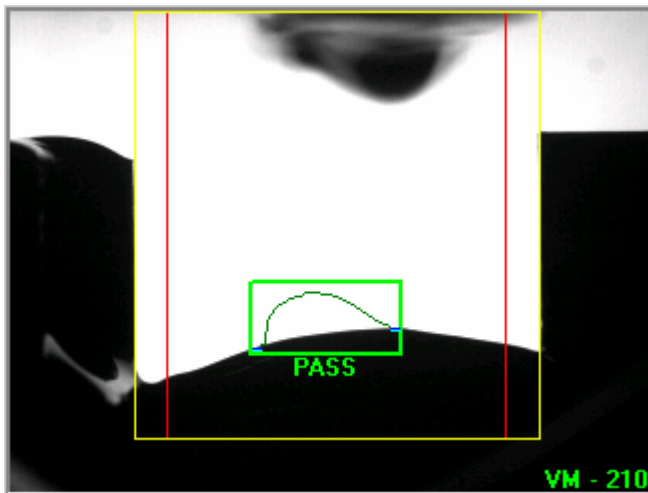

After the marker attempts to remove the fin a second image is taken. This image is called the Verify Mark Image. This image shows the fin area box, adjusted for any possible fish movement between images and an outline of the top of the removed fin. If the mark was successful, the fin area box and the fin outline will appear green, and the word pass will be shown below the fin area. If the mark was not successful, the fin area box and the outline of the fin will appear red, and the word fail will be shown below the fin area. To determine success, an

estimate of the percentage of fin removal is calculated by the computer. In the lower right corner of the Verify Mark Image, the fish number is displayed.

Marking and Tagging Errors:

During normal operation mode, many errors and messages are generated. The most common errors are described in this section. Some errors may occur which are not described here, but they are typically uncommon and are for developmental purposes. If a particular error shows up regularly which is not described here, please notify NMT.

Every error is displayed on the 'Errors' tab. The errors list saves the most recent errors and displays the age of that error in number of fish. The most recent error is always shown on the main line controller window. In some cases, common errors are also displayed on the image window as a set of 2 or 3 large red initials. The cross reference of these initials and their corresponding errors are shown in Table 1. Problems with mechanisms are accompanied by a set of 2 initials displayed in the image window. The cross reference for these initials to their corresponding mechanism is shown in Table 2. The corresponding errors are always available on the error list.

PAR Parolee	
TF Tag	Failure
FLG	Slide to Lower Gate Timeout
FUG	Fish Stuck at Upper Gate

Table 1: Fish Errors

CL Clipper	
WD Water	Diverter
FC Front	Clamp
LG Lower	Gate
MX Marker	X
MY Marker	Y
RC Rear	Clamp
TD Trap	Door
UG Upper	Gate
TW	MKIV Problem- Check Wire

Table 2: Mechanical Errors

★Description of Errors

Already in cal state: The calibration button has been pushed and while in the calibration state, the button was pushed again.

Cannot find fiducial left edge: During calibration, the computer failed to find the left edge of the fiducial. The camera needs to be adjusted slightly to the left or right to ensure that the left edge of the fiducial can be found.

Cannot trace fish back: During the Find Fin Imaging process, the fish back could not be traced.

Clamp image does not match config: The image of the clamp window is not the expected size.

Com error X: There are several communication errors that may occur that are uncommon and rarely associated with a processing error. Each of these errors will have a number in place of the X. If this error is occurring on a regular basis, NMT should be contacted immediately with the associated numbers.

Could not find Fiducial: The vision system could not identify the fiducial in the marker image.

Fin too short: The fin height is shorter than the minimum fin height as set in the global fish settings.

Fin too skinny: The fin width is smaller than the minimum fin width as set in the global fish settings.

Fin too tall: The fin height is taller than the maximum fin height as set in the global fish settings.

Fin too wide: The fin width is larger than the maximum fin width as set in the global fish settings.

Fish moved: The fish moved too much between the Find Fin Image and the Verify Mark Image. The vision system was not able to adjust the fin area for verification.

Fish paroled: The fish was released from the lower gate but did not trigger the nose sensor within the allowable time.

Fish stuck at upper gate: The upper gate attempted to release a fish, but the fish was not detected crossing the sensor below the upper gate. The fish is still detected above the upper gate.

Fish too long: The fin, which was found by the vision system, was too close to either side of the clamp window for the blade to adequately remove the fin.

Fish too short: The fin, which was found by the vision system, was too close to the right side of the clamp window for the blade to adequately remove the fin.

Insufficient fin removal: The Verify Mark algorithm determined that the minimum fin area to be removed, by percentage, was not met.

Marker cal fid outside area: The location of the fiducial was determined, but it was not within the expected area.

MKIV not ready: The MKIV is not in a ready state.

MKIV offline: The line was attempted to run with the power off on the MKIV.

MKIV Problem check wire: The wire in the MKIV has either jammed or run out.

Motor X homing error: Motor X is replaced with one of the nine motors. While running or during calibration the motor attempted to home and the homing procedure failed.

Motor X offline: Motor X is replaced with one of the nine motors. A communication breakdown has occurred between the driver interface and the line controller board.

Motor X stalled: Motor X is replaced with one of the nine motors. During the operation of the mechanism, the motor stalled.

No fish back: The Find Fin algorithm could not find a suitable edge in the expected area to begin tracing the fish's back.

Slide to lower gate timeout: The upper gate released a fish, and the fish was detected crossing the sensor below the upper gate, but did not arrive at the lower gate within the allowable time limit.

Stopped too many FFFs: The line was stopped because there were three Find Fin Failures in a row.

Stopped too many parolees: The line was stopped because there were three Parolees in a row.

Stopped too many Tag Failures: The line was stopped because there were three Tag Failures in a row.

Stopped too many VMFs: The line was stopped because there were three Verify Mark Failures in a row.

System not on line: The Line Controller cannot communicate with the line.

Tag failure: The MKIV delivered a tag but it was not detected by the QCD prior to the next MKIV cycle.

Unrecognized statement X Y: The line sent some information to the computer that it did not understand or vice versa. Each of these errors will have a number in place of the X and Y. If this error is occurring on a regular basis, NMT should be contacted immediately with the associated numbers.

AutoFish Marking and Tagging Line Components

All of the parts of the clipping and tagging line work in conjunction to adipose fin clip and coded wire tag juvenile salmonids. In order to operate the trailer in an efficient manner, the operator must become familiar with all of the components and their functions. The following are diagrams and descriptions of the major components of the line.

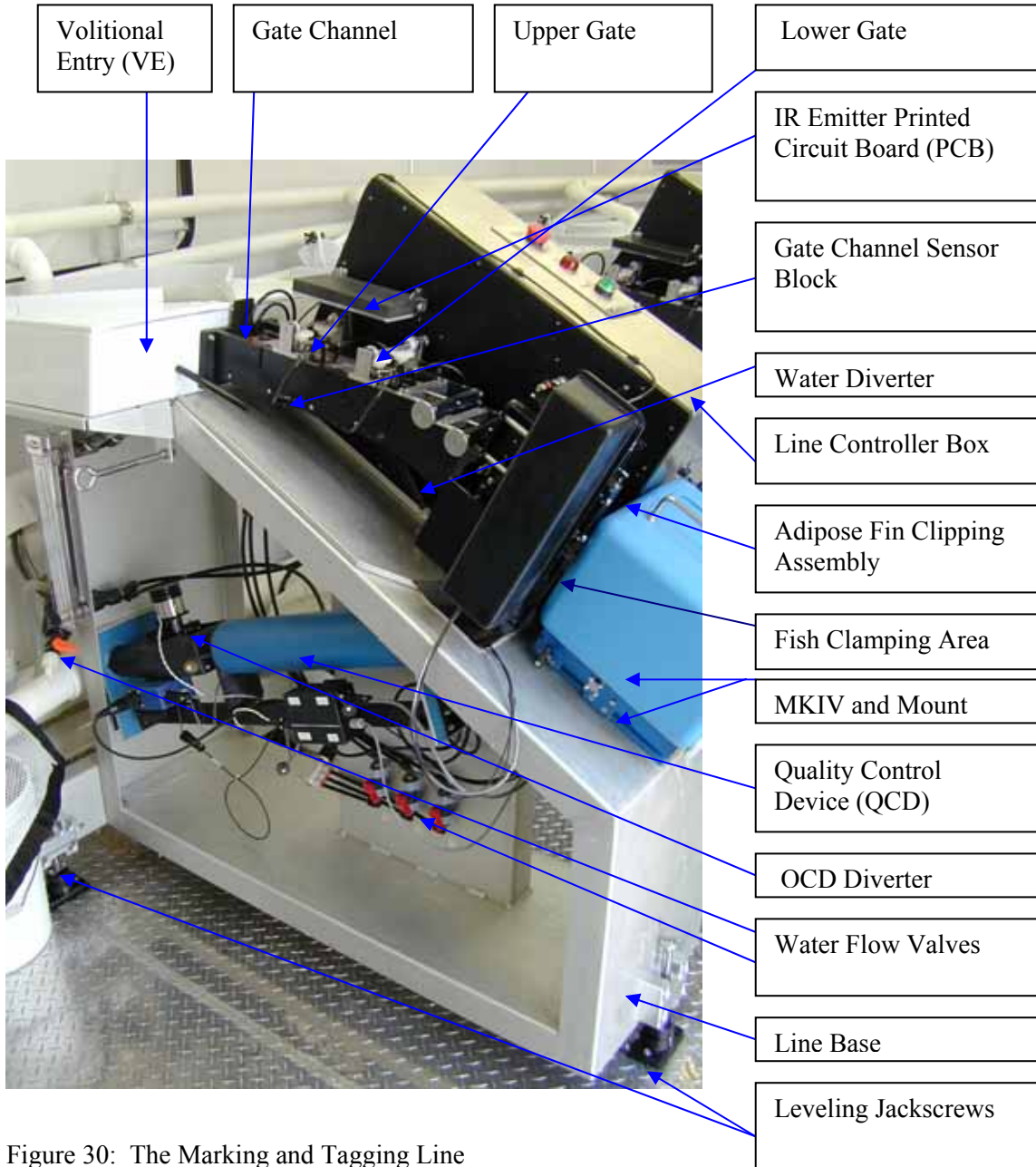

Figure 30: The Marking and Tagging Line

Volitional Entry (VE):

The marking and tagging line VE is the receiving basin and staging area for fish (Figure 31) prior to entering the gate channel. The water is supplied to the line VE in the front and drains out the rear of the VE to aid in head first and back up orientation.

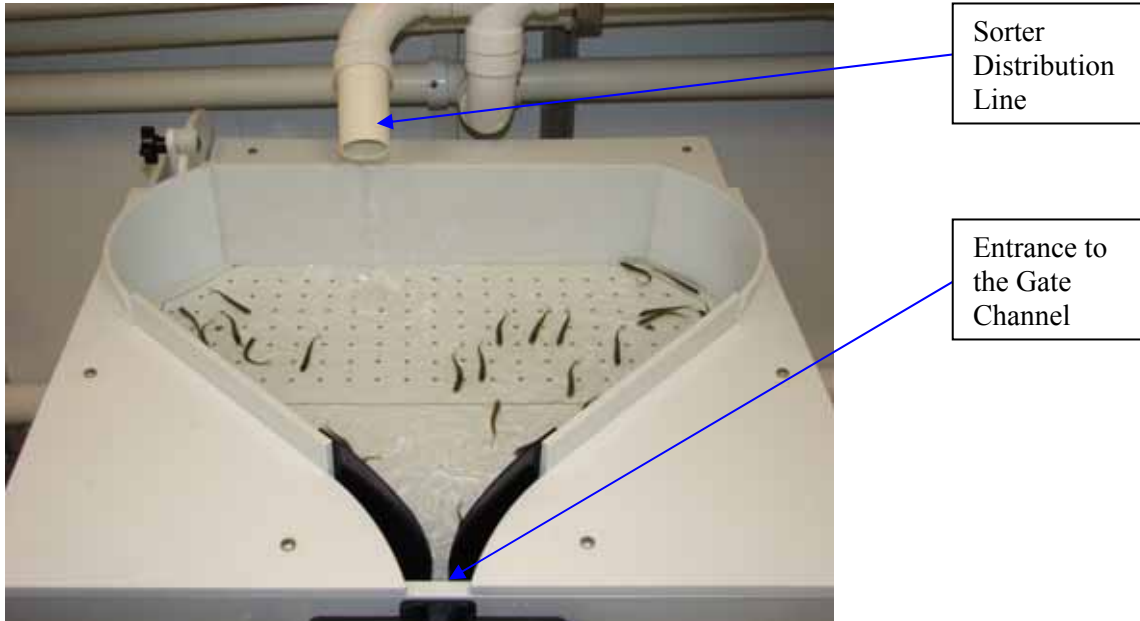

Figure 31: Volitional Entry

Gate Channel:

The gate channel mechanism, mounted to the line controller box and VE shown in Figure 30 controls the fish between the VE and the processing area. The internal walls and top of the gate channel are manually adjusted for different sized fish. The channel height and width adjustments are made by turning the appropriate adjustment knob on the side of the channel.

★Line Water Flow and Booster Pump

Water is added in three separate locations of the gate channel: above the upper gate, between the upper and lower gates and below the lower gate. The water flow is controlled by the flow valves mounted on the line base below the channel. To adjust the water flow to the channel, remove the desired water line and adjust the corresponding valve until the desired flow is attained.

The gate channel, fish ejector solenoid, and the fin washer solenoid are supplied water from the lines booster pump located below the front trough. The booster pump draws water from the sump area of the trough, boosts the pressure, and delivers it to the gate channels and solenoids. This ensures constant and reliable water flow to these critical areas. The booster pump pressure gauge is mounted just behind line 1 and should read between 30 and 40 psi while operating.

The main power switch for the lines booster pump is located on the front wall of the trailer. The power for the lines booster pump may be turned on once the front trough is full. In the event the

booster pump is run without water and/or loses its prime, it may be re-primed using the following procedure.

1. Turn off the power to the lines booster pump.
2. Open the priming valve on top of the booster pump.
3. Ensure a solid flow of water from the priming valve.
4. Close the priming valve.
5. Turn on the power to the lines booster pump.
6. If the pump does not turn on press the yellow re-start button located on the pump.

The lines booster pump has a filter on the intake line that should be cleaned periodically. If the booster pump pressure begins to drop much below 30 psi the filter may need to be cleaned. The filter may be cleaned using the following procedures.

1. Turn off the power to the lines booster pump.
2. Close the valve located between the trough and the booster pump filter.
3. Un-screw the clear filter housing making sure not to lose the large black O-ring.
4. Remove the filter and wash off any debris.
5. Re-install all pieces.
6. Open the valve located between the trough and the booster pump filter.
7. Turn on the power to the lines booster pump.

★Upper and Lower Gate

There are two fish control gates within the channel. The upper gate is the gate located closest to the VE. The upper gate is designed to ensure the passage of only a single fish down to the lower gate. The function of the lower gate, located downstream of the upper gate, is to hold the fish until the processing area is clear and prepared for the next fish. The upper and lower gates are easily removed from the channel by loosening the two thumbscrews which secure them to the side of the channel.

★Sensors

As fish travel through the gate channel their location is tracked using sensors. The sensor system on the gate channel consists of two parts; the infrared (IR) emitter PCB and the sensor block. Mounted just over the gate channel is the IR emitter PCB (Figure 30) which emits light through the clear gate channel cover and interfaces the sensors mounted below the channel. Once the fish breaks the light connection between the emitter and the sensor, the software then knows the location of the fish within the gate channel. There is a sensor just above the upper gate, eight sensors between the upper and lower gate, and one sensor at the lower gate.

Line Controller Box:

The line controller box is a watertight stainless steel box mounted on the line base which houses the electronics for each line. Each line contains the following equipment along with the necessary connections.

★Line Controller PCB



The line controller PCB directs all of the marking and tagging operations. All motors and sensors are directly attached to the line controller. A small board called the Rabbit is attached to the right hand side of the Line Controller. The Rabbit is used to download software to the marking and tagging lines.

★Stepper Motor

The stepper motor, sensor, home sensor flag, driver, and driver interface work in conjunction to operate each of the mechanisms that run the marking and tagging lines. Stepper motors are electrically driven motors that are capable of moving the mechanisms in precise steps. There are nine stepper motors in each line controller box. Three are used for the fish holding operation, two for the fish control gates, two for the vertical and horizontal movement of the fin clipping mechanism, one for the clipper, and one for the water diverter. The layout of the stepper motors in the control box is shown in Figure 32. When the power to the line is off, or the specific motors have been disabled with the handheld, the motors can be easily rotated into any position by hand. With the power on, there is a holding torque on each of the motors, which make them difficult to move by hand. As a standard practice; mechanisms should only be moved by hand with the power off or when placed in the disable mode.

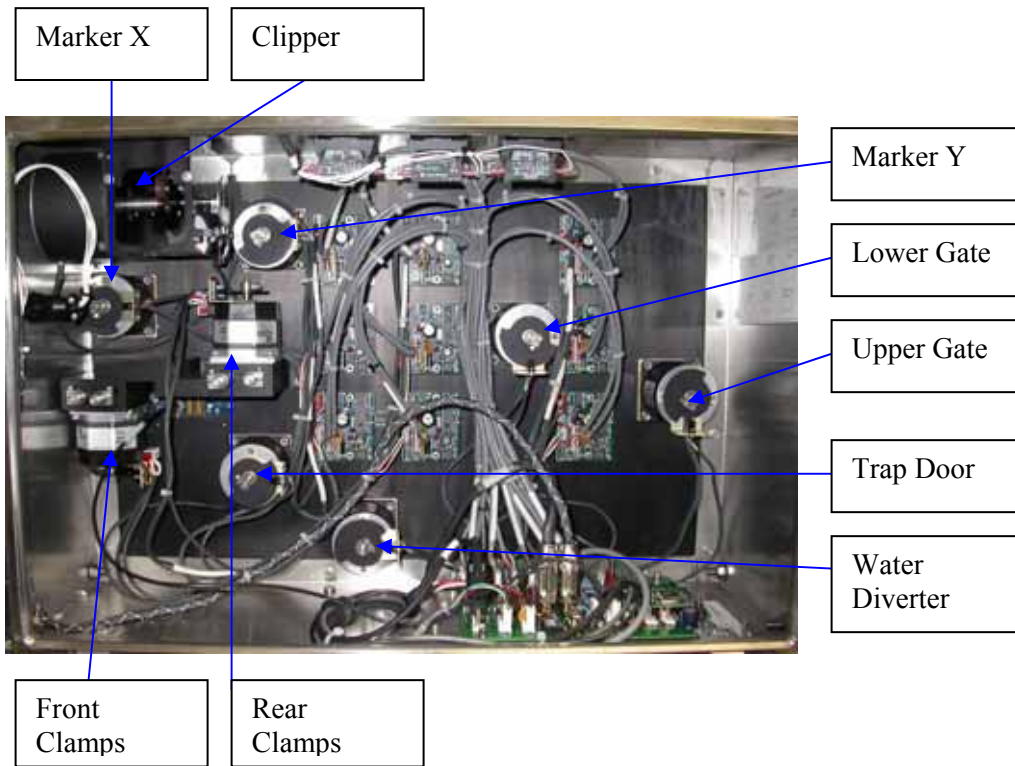

Figure 32: Stepper Motor Layout

★Stepper Motor Interface



The stepper motor interface controls all motions and the homing of the stepper motors and directly communicates with the line controller PCB. Each stepper motor has a stepper interface associated with it. The board layout is also diagrammed in each control box as shown in Figure 33.

★Stepper Motor Driver



The stepper motor drivers provide the necessary power so the computer can control the motor positions. There is a separate driver for each motor connected directly to the back side of each stepper motor interface. Between the driver and the line controller box is an insulator which provides protection to the electrical components.

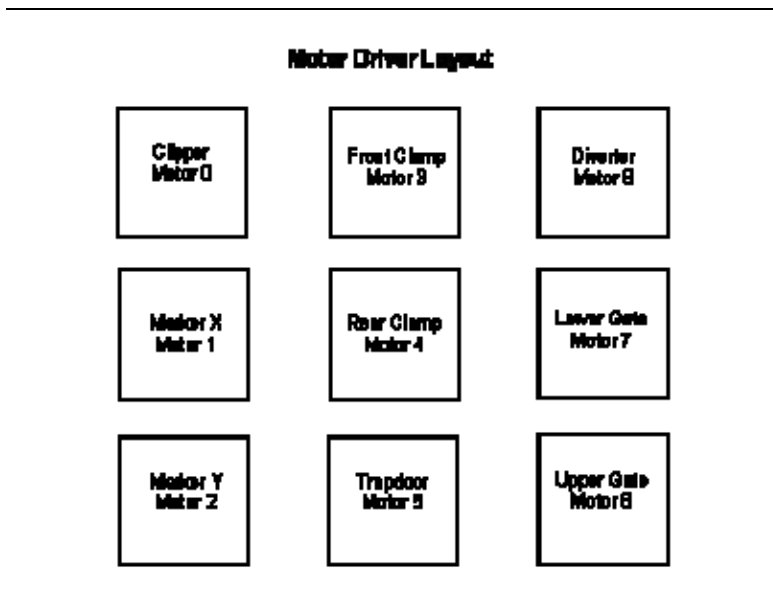

Figure 33: Motor Driver Layout

★ Home Sensor and Home Sensor Flag

A home sensor is attached to each of the motors and works in conjunction with the home sensor flag (Figure 34) to determine motor positions. The flags are attached directly to the motor shafts using a split hub clamp. The home sensor is connected directly to the line controller PCB. The home position is defined as the location of the motor when the flat edge of the flag reaches the sensor. From this home position, the software then bases all motor movements.

All nine stepper motors have a unique home position. The motor function on the handheld controller is used to check the home positions. Using the handheld controller 'Home' the desired motor and compare the position of the mechanism to the home positions described below.

The clipper home and open position are the same. When the clipper is in the home position it should be in the open position.

The home position for the marker X motor centers the clipper carrier on the horizontal shafts. The measured distance on either side of the clipper carrier should be of equal distance.

The marker Y home position should position the carrier 3mm from the top of the travel range. The line stop gate can be used as a shim to check or set the home position.

With the front clamps in the home position the measured distance between the front clamp mounting plates should be 2.00 inches.

With the rear clamps in the home position the measured distance between the rear clamp mounting plates should be 1.70 inches.

The trapdoor home position is the location in which the trapdoor is completely closed. Proper positioning is best measured using the shaft in the spring linkage of the trap door. This shaft should be centered in the spring linkage when in the home and/or closed position.

The water diverter has no measurable home position. When the diverter is in the closed position it should close all the way flush with the bottom of the channel. If it does not close completely, the home position will have to be adjusted accordingly.

The upper and lower gates have the same home position. The drive arm for both gates should be parallel with the angle of the side of the line controller box when in the home position.

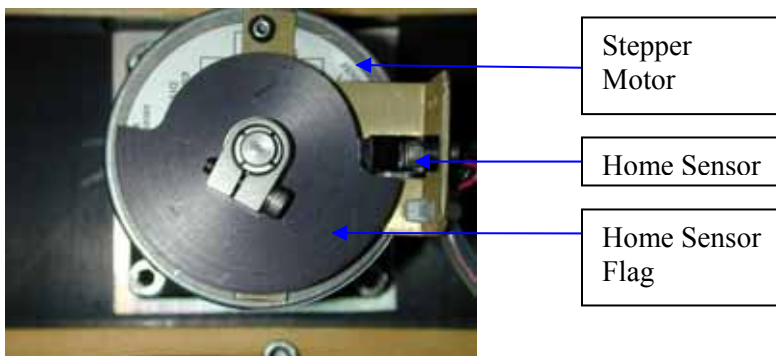

Figure 34: Stepper Motor, Home Sensor, and Home Sensor Flag

★Setting the Home Position

1. Using the motor option on the handheld controller, scroll through to the desired motor.
2. Place the motor in the current home position.
3. Using the up and down arrows on the handheld controller, step the mechanism into the desired home position as described in the previous section.
4. Loosen the hub clamp on the desired home sensor flag.
5. Place the homing tool over the edge of the home sensor flag and move the flag into the home sensor.
6. While holding the home sensor flag in position, tighten the hub clamp on the motor shaft.
7. Disable the motor and rotate the home sensor flag to remove the homing tool.
8. Re-enable the motor and check the new home position.



Adipose Fin Clipping Assembly:

The adipose fin clipping operations are carried out by several different mechanisms. The clipper drive assembly is located inside the line controller box. The cable, which attaches to the marker assembly, is routed through the control box just above the marker assembly. The cable is manually adjusted for clipping force using the tensioning nuts on the cable (Figure 35).

The marker assembly is attached to the cable and carries the blade assembly. When actuated, the cable pulls on the marker assembly and applies the force to the blade assembly required for fin clipping. The blade assembly consists of a blade and anvil cutting system.

The XY table carries the marker assembly and provides the horizontal and vertical movement for fin clipping. These movements are controlled and directed by the imaging system.

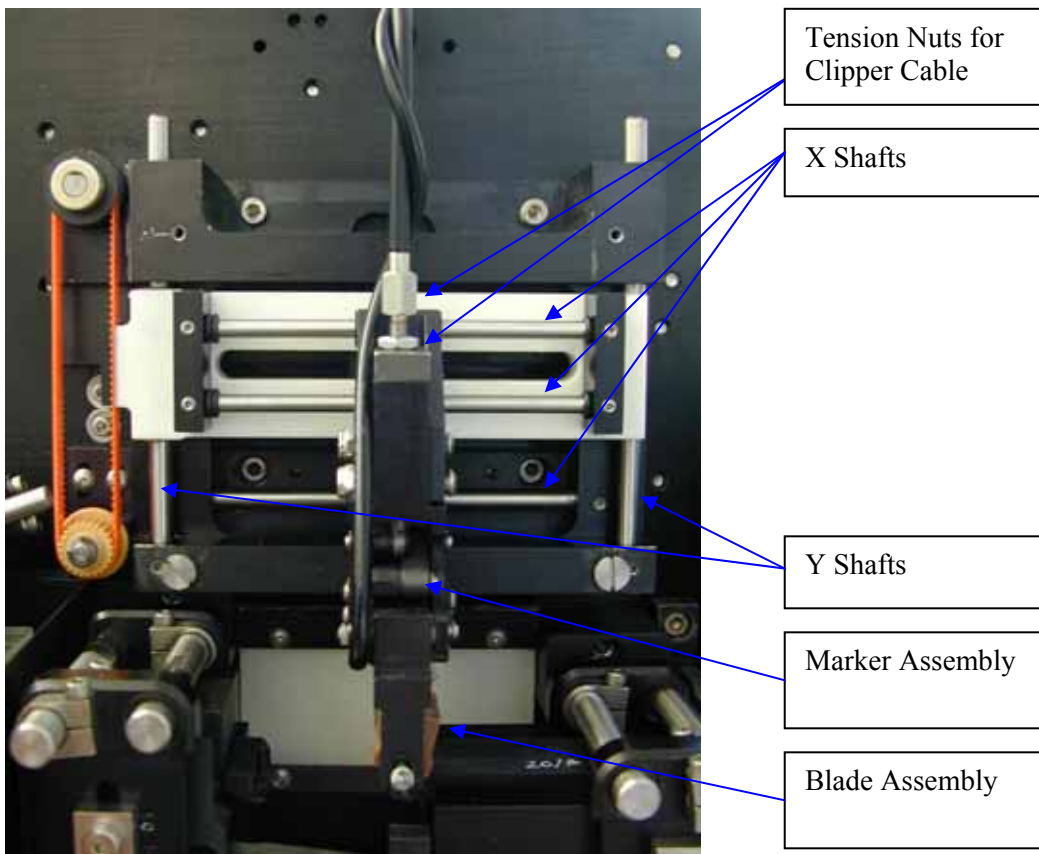

Figure 35: Adipose Fin Clipping Assembly

Imaging System:

Each line has a complete imaging system which consists of several components used to capture images of the adipose fin while in mark mode. The system consists of a camera and lens, a prism, a spinner, and a backlight. The video monitors display live images captured from the cameras.

The two main components of the adipose fin imaging system are the line camera and the backlight. The camera on the marking and tagging lines images the adipose fin of each fish so that the fin may be removed. The backlight provides a lighted back drop for imaging. The camera on each line is facing down and the image is re-directed towards the clamping area via a prism (Figure 36). The spinner is mounted between the prism and the fish clamping area to prevent water drops from interfering with the imaging process. The spinner is driven by an electric motor and flings any water it may encounter to ensure a clear imaging path.

There are two adjustments on the line cameras, the F-stop adjustment and the focus (Figure 36). The F-stop adjusts the amount of light allowed into the lens of the camera. As the F-stop is opened up, the Align image on the software will brighten, and as the F-stop is closed, the image will darken. The F-stop is adjusted by turning the adjustment ring on the camera lens as pictured in Figure 36. Once the adjustment is final, tighten the small set screw on the F-stop adjustment to prevent it from moving. After adjusting the F-stop, the imaging system should be re-calibrated as described in the marking and tagging software section. The focus adjustment on the line camera is located on the lens just below the F-stop adjustment (Figure 36). The focus on the line camera should always be adjusted to the far setting.

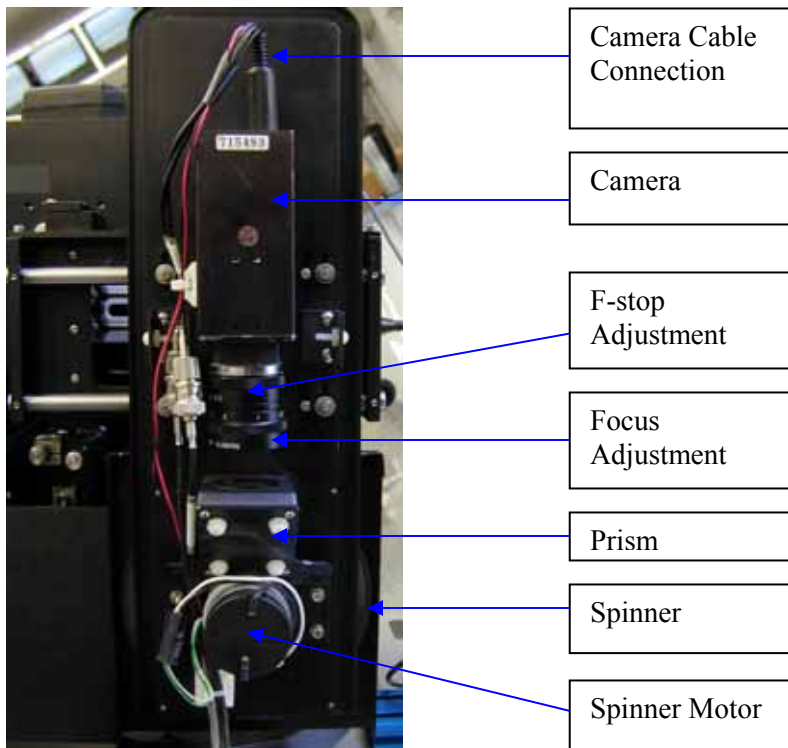

Figure 36: Adipose Fin Imaging Camera

Fish Clamping Area:

The marking and tagging takes place in the fish clamping area of the line. This is composed of several parts that require precise adjustments.

★Holder Mechanism

The holder mechanism is a rack and pinion system to which the fish adapter plates are attached. This mechanism opens and closes to hold the fish for processing. Most of the holder mechanism is inside the line controller box with only the shafts (racks) protruding from the box (Figure 37).

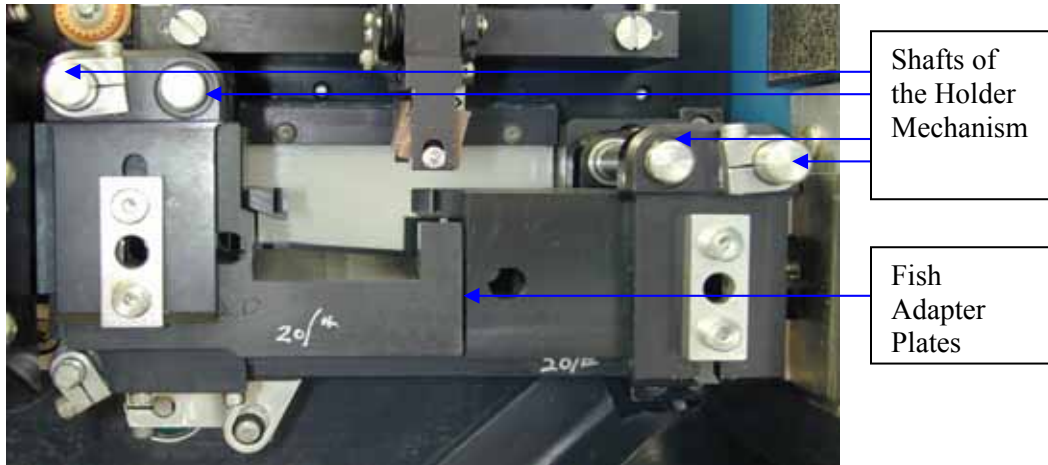

Figure 37: Holder Mechanism and Fish Clamping Area

★Fish Adapter Plates

Fish adapter plates are size specific sets of parts precisely designed to hold the fish for processing (Figure 38). The foam lined fish adapter plates are connected directly to the holder mechanism. The plates come in sizes for 250, 200, 160, 120, 105, 90, 78, 65, 55, 45, 38, 30, 25, and 20 fish per pound. Each set consists of a head mold, trapdoor, a left and right front and rear clamp, and four aluminum adapter plates that mate the clamps with the foam pads.

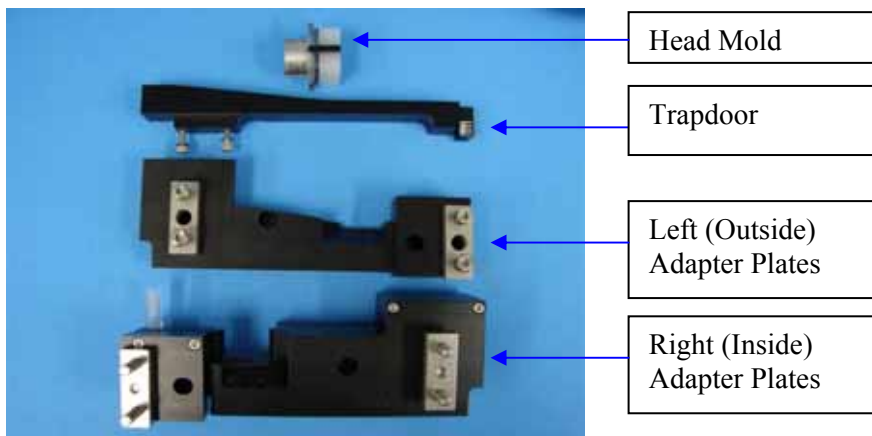

Figure 38: Set of Fish Adapter Plates

★ Water Diverter

The water diverter, shown in Figure 39, is a trapdoor mechanism located at the end of the gate channel which drops down during the clamping process to divert the water from the clamping area. Excess water in the clamping area may interfere with the imaging process while adipose clipping.



Figure 39: Water Diverter

Water Flow Meters and Valves:

Attached to the line base are several water flow meters and valves. The large meter at the rear of the line controls the main water supply to the VE and should be set at 5.5 gpm. The small valves on the line base control the water supply to the three sections of the gate channel and are adjusted to optimize fish movement through the channel. There is also a small valve located on the line base that controls water pressure to the fish ejection device.

Line Base:



The line base is shock mounted to the floor of the trailer to dampen vibrations during trailer moves. Two of the three mounting feet are equipped with leveling jackscrews. The jackscrews are used to make leveling adjustments to each of the VEs on the marking and tagging lines.

Mark IV (MKIV):

The MKIV is the machine that performs the tagging operation on each line. The machine uses a 24 gauge needle to insert a coded wire tag into the snout of each specimen that enters the head mold. Each tag is individually cut and magnetized prior to insertion. A MKIV manual is provided in every trailer for troubleshooting and general maintenance. Read this manual to become familiar with MKIV operations.

★ Differentiating AutoFish MKIVs

The AutoFish version of the MKIV has some extra internal circuitry. The display screen should read version 4.5a or above. Earlier versions of MKIVs should not be used with the AutoFish System. The AutoFish MKIVs have a tag failure LED on the top near the display screen and do not have a blue tag switch on the front of the machine. These are two good ways to externally differentiate between the non-compatible versions.

★ MKIV Mating Plate



The MKIV mating plate provides precise positioning of the injector relative to the fish adapter plates. The MKIV collar and attached head mold mate with this adjustable part. This plate is equipped with an indicator mark to use as an interface with the adjustment gauge on the adjacent mounting piece. This piece also serves as an indicator that the MKIV is properly seated and ready for operation. When the MKIV is moved up into position, the MKIV collar should be flush with the inside surface of the mounting plate.

★ Adjusting the MKIV

The only special MKIV adjustment required for the AutoFish System is the position of the needle bevel. The needle bevel should be in the upward direction when used in the AutoFish System so the entire surface of the bevel does not contact the surface of the snout at once. This has a tendency to do more tissue damage to the fish. With the needle bevel facing in the up position, the needle creates a flap of skin that heals quicker.

The MKIV mount maintains the alignment of the MKIV coded wire tag injector with the other line components while providing the necessary adjustments for accurate tag placement. The AutoFish MKIVs are equipped with a plate that is used to fasten the machine to the mount. This plate should not be removed as water intrusion may damage the internal components of the machine. The MKIV can be adjusted vertically, according to where the MKIV mating plate is set. This adjustment is made with the dial at the end of the MKIV located on the mounting bracket in which the MKIV is fastened as pictured in Figure 40. Turning this dial in a clockwise fashion will raise the MKIV and counter-clockwise rotation will lower the unit.

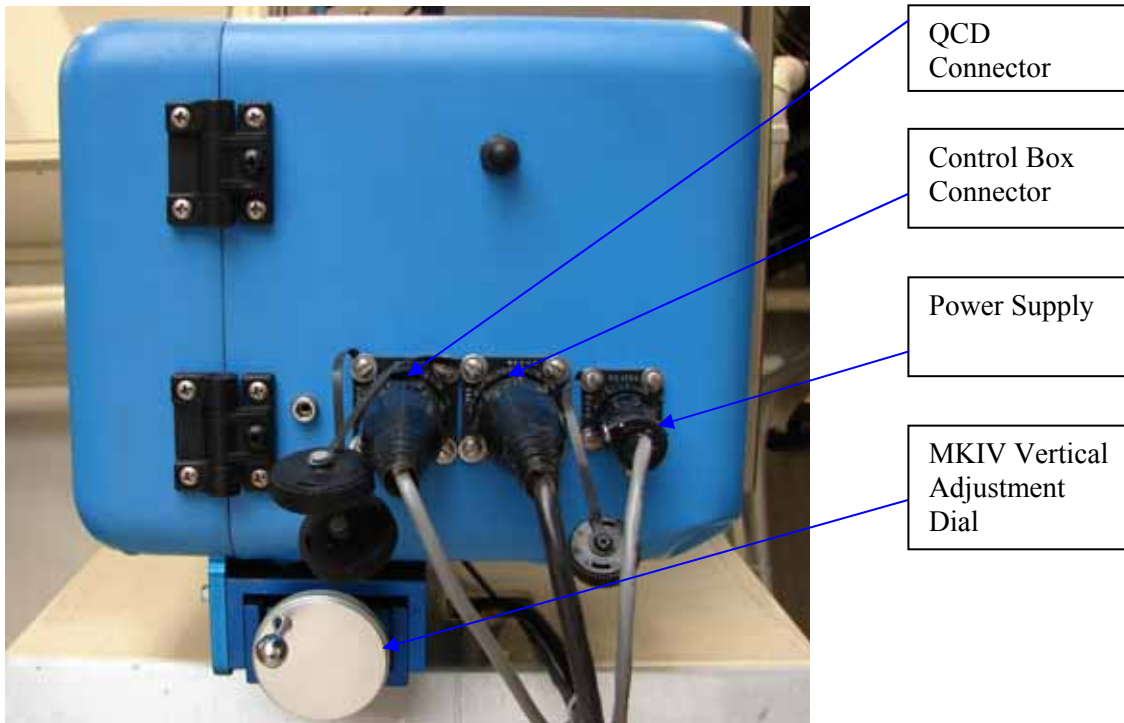

Figure 40: MKIV Connections and Vertical Adjustment Dial

★MKIV cutters

The number on the MKIV cutter (located on the pin and the sleeve flange), should be recorded in the yellow notebook located in the inside cover of the MKIV. Cutters are manufactured with a pin and sleeve as a matched set, so it is important to keep the two pieces together. Mixing them with other cutter parts will significantly reduce the life of the cutter.

The cutter (with pin and sleeve separated) should be removed from the MKIV and stored in a 70% alcohol solution at the end of every work day. The MKIVs in the AutoFish trailers are mounted at an angle which allows water and fish slime to accumulate in the working parts. Over time, this buildup may cause unnecessary wear on moving parts if regular maintenance is not performed.

★MKIV Head Mold Simulator

When operating the AutoFish trailer in Mark Only mode, the head mold simulator may be used in place of the MKIV. Install the head mold, with the sensor and emitter securely attached, into the head mold simulator. The simulator can now be attached to the MKIV adapter plate. Figure 43 displays how to connect the line controller to the QCD cable when the MKIV has been removed. All line controllers must also be changed to MKIV 'Absent'.

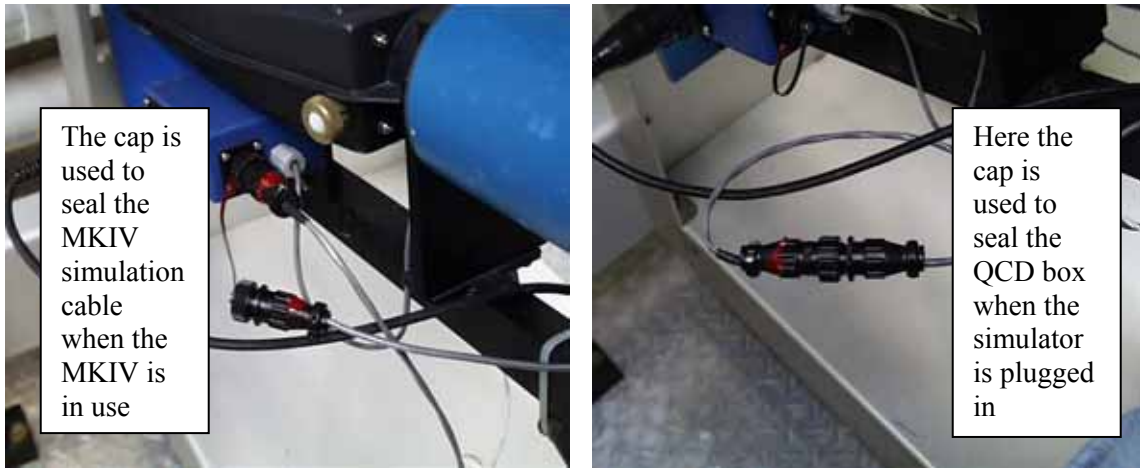

Figure 43: MKIV Head mold Simulator Connectors

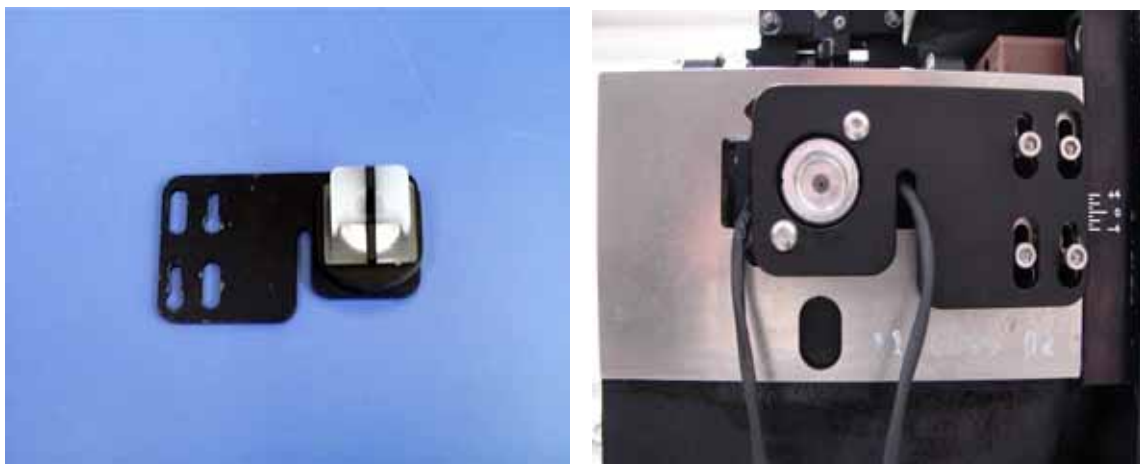

Figure 44: MKIV Head mold simulator with head mold and installed on the line

Quality Control Device (QCD):

The QCD detects the presence of a magnetized specimen as it passes through the detection head. The QCD is mounted to the line base and is plumbed into the main trailer discharge line.

The QCD separates tagged and non-tagged, clipped and non-clipped fish after they pass through the detection tunnel. When in coded wire tagging mode, the QCD detects tags as they pass through the tunnel. During marking, the QCD receives information from the computer to determine the success of each fish.

A mechanical QCD diverter is located between the QCD and the discharge line and functions in separating the rejects from the successfully processed fish. A fish passing tag/mark verification

will be directly diverted to the receiving pond and fish failing the tag/mark verification will be diverted into the reject containment system. Fish that are rejected will need to be reprocessed. The QCD's default setting diverts fish into the reject bucket.

When tagging, the QCD interacts with the MKIV to notify the operator when a fish has passed through the QCD without a tag. The MKIV will beep letting the operator know the MKIV was cycled, but a tag was not detected prior to the next cycle.

In general, the QCD is very reliable and trouble free. If more detailed operational information or troubleshooting techniques are needed reference the MKIV manual. QCD problems that may be encountered are:

1. Bad power cable between MKIV and QCD. In this case replace with the spare cable.
2. Gate not activating.
 - a. Getting signal from MKIV? If not, the MKIV may need to be serviced.
 - b. Check power cable.
 - c. Make sure that cabling is correct.
 - d. Make sure software setting for MKIV is correct.
3. Fish not diverted properly. In this case, ensure that the gate is functioning properly.

★QCD Diverter Adjustment

The QCD diverter gate may need periodic adjustment. Following are instructions to make any adjustments or changes to the QCD diverter.

1. Loosen the four screws on the coupler and the two screws that hold the bumpers in place (Figure 41). Tighten the two upper screws on the coupler.
2. Set the right-hand bumper (stop) so that the fin tip is flush to 1/16" past the fin shield.
3. Move fin all the way to the right side, compressing (approximately 1/4") the bumper with the stop pin on fin (Figure 42). While keeping pressure on the bumper, tighten the lower screws of the coupler. This operation is done to apply a small amount of pre-load to the return spring on the actuator while in the "rest" state.
4. Using the MKIV, actuate the actuator, driving the fin over to the left side. The fin should again be flush to 1/16" past the fin shield. This can be done by pressing the SHOW button on the on the MKIV and then continually press the STEP button to cycle the diverter fin to the desired position. Slide the left side bumper in or out to establish the fin tip/fin shield relationship and tighten the stop. Cycle the actuator on and off a few times, checking to see that the fin tip /shield relationship is still correct on both the right and left positions.
5. Check device for binding. The fin should snap back quickly on the return spring with no binding.

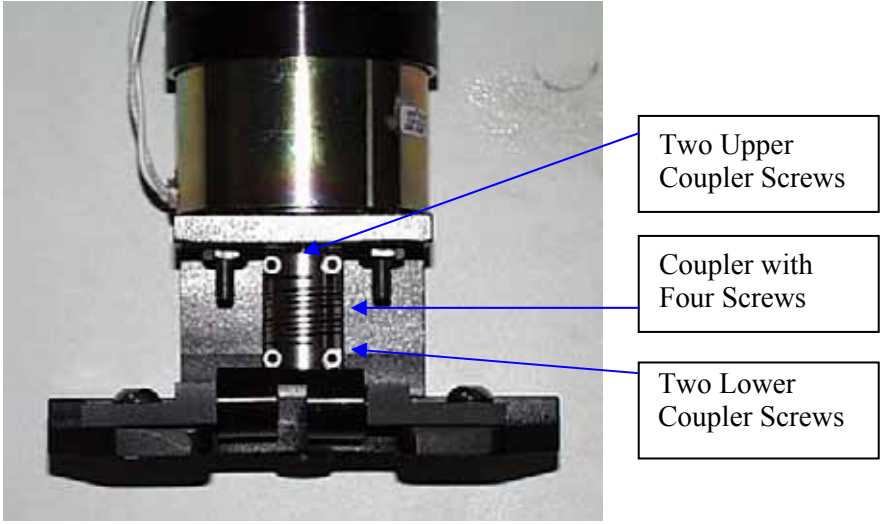

Figure 41: QCD Diverter and Solenoid

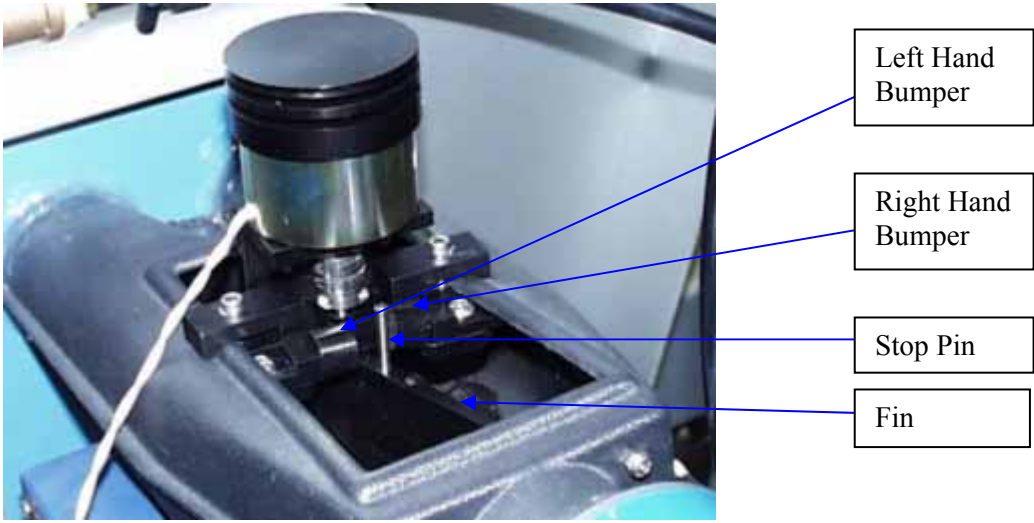

Figure 42: QCD Diverter

Preparing the Sorter and the Lines to Process Fish

After the initial trailer setup is complete, the sorter and the marking and tagging lines may be prepared for processing fish. Transport a random sample of approximately 1000 fish into the holding trough to begin the process.

Leveling the Lines and Sorter:

There are two leveling mechanisms on each of the line bases and on the underside of the sorter stand. Using a small torpedo level placed on the floor of each volitional entry near the fish exit, level all of the VEs side to side. For proper water flow, the line VEs should be slightly higher at the VE exit. The sorter VE should be level on all planes. This is a good starting point but may need to be adjusted according to the behavior of individual groups of fish.

Water Flow:

★System

The main fish holding trough should receive approximately 20 gpm. The fish pump uses water from the trough but is quickly recycled through the dewatering device. The intake for the booster pumps is at the tail end of the trough. For this reason, it is necessary to make certain that there is water flowing over the stand pipe at all times so the booster pumps do not drain the trough. This is controlled by adjusting the valve under the trough at the front of the trailer. The back trough valve should be adjusted about ½ open. There are two 4" main outflow pipes. The top pipe transfers fish to the destination ponds and the lower pipe transfers overflow water only.

★Sorter

The sorter has one large flow meter which supplies water to the VE. This flow meter should be set at 6.0 gpm. The water level in the VEs should be set just above the dorsal fin. This adjustment can be made using the adjustment knob on the rear of VE.

Each of the transitions use two flow meters that are supplied water through the high pressure system via the booster pump. This booster pump pressure should remain between 50 and 60 psi during operation. The four flow meters control and indicate the water flow to the transitions and the water jets.

To set the jet-flow to the desired pressure, press the 'Disinfect' button on the main sorter screen to activate both jets. While the jets are activated, the necessary flow adjustments can be made using the corresponding flow meter. Once the proper flow is set, press the 'Disinfect' button again to disengage the jets. The transition water may be adjusted anytime as this is a constant flow. The following is a good starting point for initial sorter water settings.

Fish Size	Transition Water	Jet Flow
250-120/#	1.0-2.0 gallons per minute	0.5-1.0 gallons per minute
90-55/#	1.5-2.5 gallons per minute	1.0-1.5 gallons per minute
45-20/#	2.0-3.0 gallons per minute	1.0-2.0 gallons per minute

Typically, larger fish will need more flow in both the transition and the jets to provide adequate separation. Again, these settings provide a good starting point and may need to be adjusted according to the behavior of individual groups of fish.

The distribution pipes transport fish from the sorter to each of the line VEs. Each pipe has an individual water source and valve. The water in each of these pipes should be adjusted as high as possible without adding so much water that the dewatering devices at the end of the lines become ineffective. Too much water will disturb the intended flow in the VE which is key for proper fish orientation.

★ Lines

Each of the lines has one large flow meter which supplies water to the VE. This flow meter should be set at 5.5 gpm. The water level in the VEs should be set just above the dorsal fin. This adjustment can be made using the adjustment knob on the rear of VE.

The gate channel, the fish ejection device, and the fin washer are all supplied water through the high pressure system via the booster pump. The booster pump pressure should remain between 30 and 40 psi during operation. The 3 small valves on each line that supply water to the gate channel should be set according to the fish size and will be adjusted once fish are being processed. To check the water flow within the gate channel, it is necessary to remove the tubing from the fittings to visually examine the flow. To remove the tubing, push down on the top of each fitting and pull upward to remove the tubing. The valve that controls the water for the fish ejection device should also be visually examined. While processing small fish (<90/#) it may be necessary to decrease the water pressure by closing the valve slightly.

Determining Fish Size for Setup:

Adjust wires and the roofs in both transitions according to the approximate fish size. The wires should be adjusted as close as possible in order to provide adequate separation. Adjust the water jets according to the following recommendations:

Fish Size	Type of Jets		Jet Angle
250-120/#	Two-hole	30	degrees
90-55/#	Two-hole	20	degrees
45-20/#	Three-hole	15	degrees

These settings provide a good starting point and may need to be adjusted according to the behavior of individual groups of fish.

Plug the air compressor into the front of the trailer. Close the drain cock on the bottom of the tank, attach air hose, and turn the power on. The pressure regulators attached to the valve boxes should both read 50 psi. This pressure may be adjusted by pulling the top piece of the regulator upward, making necessary adjustments, and pushing back into the downward position.

Estimate fish size and configure the ports of the sorter to handle the estimated size range. Make certain that there are no gaps in the setup and that the big and small ports are configured correctly. Engage the Sample option in main sorter window. Turn the fish pump power on and push the 'Pump On' button on the main sorter window. Set the VE density to 50% and push the 'System Feed' button to deliver fish to the sorter VE. The 'System Feed' button will be colored green when the feed is on and red when the feed is off.

As the fish are being measured, make certain that the head and the tail of each fish are being found accurately. Also make sure that there is no turbulence or water drops interfering with the edge detection of the head and the tail.

While the sample fish are being sorted, make changes to your ports to accomplish the three goals:

1. Cover as much of the distribution as possible with the six lines.
2. Even out the percentages going to each of the six lines.
3. Raise the minimum default setting 1-2 mm on each line.

Once the proper fish sizes are determined, the lines may now be setup and configured accordingly.

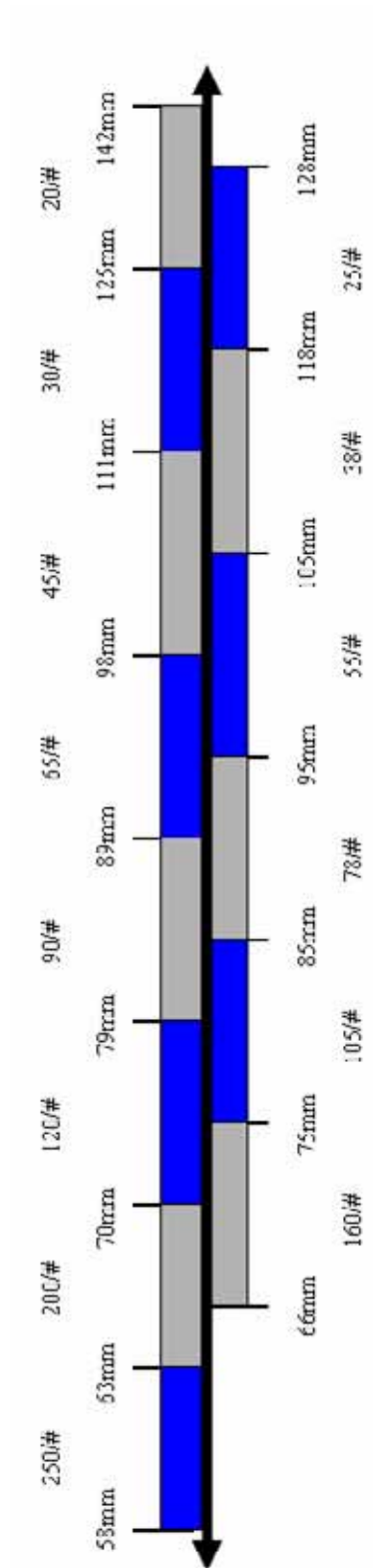

Figure 43: Fish Sizing Chart

Using the Handheld Controller:

The Handheld Controller is a diagnostic tool that may be used as an interface with the line during setup and while processing fish. The handheld can be used to change the settings of the mechanisms or sensors at any time. Once settings are changed on the handheld, they are immediately updated in the software and are effective on the next fish processed.

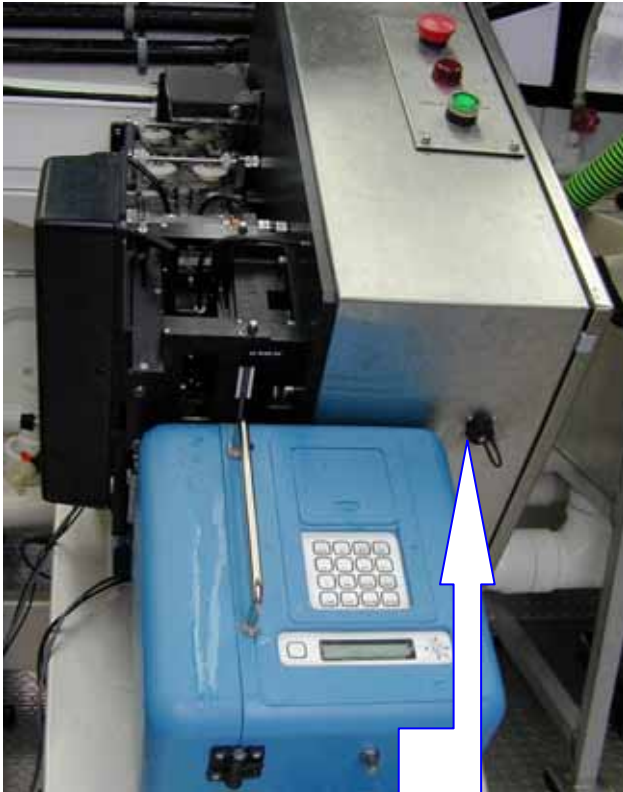

Figure 44a: Handheld Plug

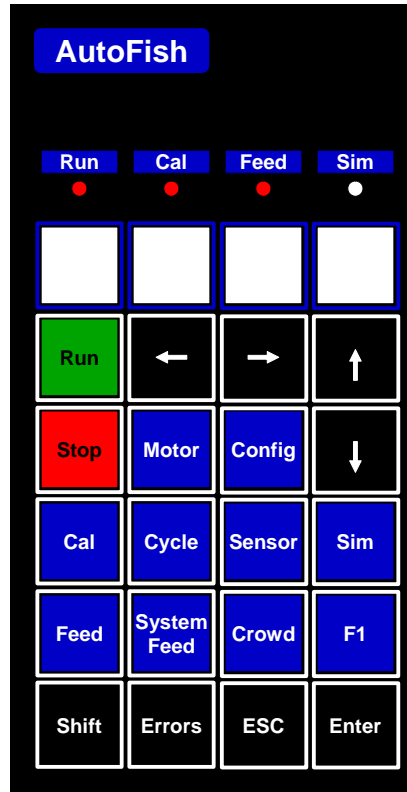

Figure 44b: Handheld Controller

There are eleven commands available for operator use on the handheld keypad which include; Run, Stop, Calibrate, Simulation, Sensor, Motor, Configure, Line Feed, System Feed, Errors, and ESC. The operator may control most of the critical settings using these commands. These commands are accessed by using the corresponding keys of the keypad as shown in Figure 44b.

The left, right, up and down arrows are used to scroll through menus or to make changes to the current values displayed on the screen. The top four white keys on the keypad correspond with the current values or commands directly above on the display. The section below details each of the functions and their associated commands.

The Handheld Controller receives power when plugged into the line control box as pictured in Figure 44a. When it receives power, the 'Status' of the line will appear in the display window. The main display also contains two command options; Clamp and Zoom. When the Clamp command is pushed once, the trapdoor will move into the closed position. When the Clamp command is pushed a second time the clamps will move into the closed position. When the

Clamp command is pushed again, the clamps and the trapdoor will move into the open position. The Zoom command is used to enlarge the imaging window of that particular line.

★ Starting and Stopping the Line



The line may be started and stopped using the 'Run' and 'Stop' key on the handheld controller. They work similarly to the green lighted button on the line controller box although the line must be calibrated in order to use these controls.

★ Calibration



The lines may be calibrated using the 'Cal' key on the handheld controller. If the line is already calibrated, one touch of the 'Cal' key will calibrate only the motors. When the 'Cal' key is touched twice in rapid succession, the motors and the vision system will be calibrated. The operator must still ensure that the vision system has been properly calibrated using the calibration images on the touch screen. The operator may view the two enlarged calibration images by pressing the white button that corresponds to Zoom on the display continuously until the desired image is shown.

★ Simulation



The line may be operated in simulation using the 'Sim' key on the handheld controller. The line must be stopped prior to engaging the Simulation mode. The red Simulation light will be illuminated at the top of the keypad indicating that the line has been placed in Simulation mode. There is no need for recalibration prior to simulation. All fish should be removed from the line prior to operating in this mode.

★ System and Line Feed



System Feed and line Feed may be controlled by pressing the 'System Feed' and 'Feed' keys respectively on the handheld. The red Feed light will be illuminated at the top of the keypad indicating that the line Feed has been activated. The indicator for System Feed is on the sorter touch screen and will be shown in green when the System Feed is on and in red when the System Feed is off.

★ Displaying Errors



A list of current errors may be displayed using the 'Errors' key on the handheld.

★ Escape



Touching the 'Esc' key allows the operator to exit out of any mode on the handheld controller.

★Sensors Function



The sensor function and sensitivity may be tested and adjusted using the ‘Sensor’ key on the handheld controller. There are 11 Infrared Emitters and Sensors in the gate channel assembly and head mold which allow the computer to track the movement of fish through the system.

The first sensor is located above the upper gate and indicates that a fish is waiting at the upper gate. The upper gate close sensors are labeled numbers one through eight and are located between the upper and lower gate. The selected close sensor activates the upper gate to close. The lower gate sensor is located just above the lower gate which indicates that a fish is waiting at the lower gate. The final sensor in the system is the nose sensor. The nose sensor is located on the head mold and indicates when a fish is in the head mold and properly positioned for processing.

When the ‘Sensor’ key is touched on the handheld controller, the live sensor readings are displayed from left to right in the order listed above. When a sensor is blocked, the handheld will display the number 1 in that specific sensor position and a 0 will be displayed when the sensor is clear of fish. The display above shows that the nose sensor is blocked as a 1 is shown in that position.

The sensitivity of the nose sensor may be adjusted by touching the up and down arrow keys while on the main sensor screen. Increasing this number will increase the sensitivity and decreasing this number will decrease the sensitivity.

The sensor that triggers the upper gate to close may also be changed using the handheld controller. The current ‘Gate Sensor’ number being used will be displayed on the main sensor screen as shown above. To make changes to this sensor, touch the left or right arrow keys until the desired sensor is chosen.

★Motor Control



The ‘Motor’ key on the handheld controller can be used to cycle or disable any of the nine motors and the solenoids. The open, close, and current motor positions (in motor steps) are displayed on the keypad in this mode. This number indicates the motor position in the number of steps from the home position. Once the ‘Motor’ key is touched, the left and right arrows allow the operator to scroll through the motors until the desired mechanism is displayed. At this time, the white keys correspond to Open, Close, Home, and Enable as shown on the display above.

The operator may disable any motor using the white key corresponding with the ‘Ena’ command on the display. This allows the user to disable any motor without powering off the line. The key must be touched again and the motor homed prior to operation of the line.

The up and down arrow keys allow the operator to move any of the nine mechanisms in individual motor steps in both directions. Again, the motor must be homed prior to operation of the line.

★Configure



Config The operator may also change the open and close position, of the clamps and gates, at any time using the 'Conf' key on the handheld controller. The open and close positions of the chosen motor are continuously displayed in this mode. The left and right arrow keys are used to scroll to the desired motor. These positions may be changed with the handheld using the white keys corresponding with the increase and decrease of the open and closed positions displayed on the screen. These settings will become effective and will be updated in the software

immediately.

Setting up the Marking and Tagging Lines:

There are 14 sizes of fish adapter plates available for use in the AutoFish System. Each size overlaps with the size above and below allowing the flexibility needed to provide equivalent numbers of fish to each line. All adapter plate sizes are labeled in fish per pound and their corresponding total length measurements are shown in Figure 43.

Using the data provided by the sample mode on the sorter and keeping in mind the three ultimate goals for setup, determine the best six sizes of fish adapter plates. Configure each line to the selected size prior to installing the plates using the Basics tab in the 'Configure' section of each line controller.

Each set of fish adapter plates consists of a head mold, a trapdoor with a head mold stop, a left front and rear clamp and aluminum adapter plate, and a right front and rear clamp and aluminum adapter plate as pictured in Figure 45.

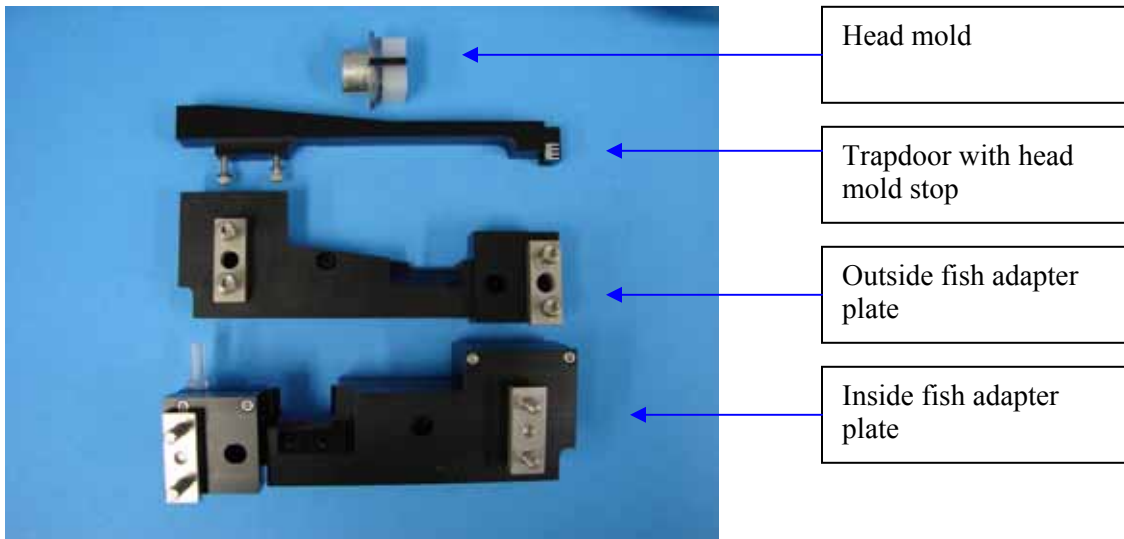

Figure 45: Set of Fish Adapter Plates

To install adapter plates, follow these instructions:

1. Install the aluminum adapter plates on the clamps. Make certain that the plates are flat against the clamps and that the edges do not protrude over the clamp edges. Each of the four plates should be secured using the two set screws on the underside of the clamp.
2. Place a belly lifter on both of the rear clamps. These pads are designed to lift the adipose fin area up into the imaging window when the clamps are in the closed position. Placing the belly lifter 1-2 mm above the bottom edge of the clamp may increase the effectiveness of the lifter.
3. Install foam pads on the adapter plates making sure that the pads are pushed all the way to the roof on the inside clamps and that they are not protruding over any edges of the clamps.



4. Using a small allen wrench, make a hole in the front and rear inside clamp to allow access to the attachment screws for installation.
5. Loosen the rear shoulder screw on the trapdoor linkage and remove the front shoulder screw from the control box. The linkage will drop down to make room for the inside clamp installation.
6. Slide the inside clamps on the mounting forks and push up to the flange on the forks. Tighten the two mounting screws.
7. Install the head mold on the MKIV (or on the MKIV head mold simulator when not using the MKIV).
8. Install the nose sensor on either side of the head mold.
9. Slide the MKIV forward, using caution not to hit the head mold on the MKIV mating plate. If the head mold does not easily slide into the mating plate, loosen the setscrews and realign or adjust the vertical position of the MKIV using the knob on the back of the MKIV mount. Turning this knob clockwise raises the machine and counterclockwise lowers the machine. It is important to make sure that the head mold is fully seated within the mating plate.
10. Reinstall the two shoulder screws on the trapdoor linkage. Adjust trapdoor stop to a suitable location and place trapdoor into linkage. Slide the trapdoor all of the way upstream and tighten mounting screws. Use the motor function on handheld controller to cycle the trap door making sure it closes completely and that it is in the proper home position. The flat spots above and below the snout-hole should have equal spacing between the roof of the clamps and the floor of the trapdoor.
11. Disable the trapdoor. Loosen the rear shoulder screw on the trapdoor linkage and remove the front shoulder screw from the control box. Drop the linkage down to make room for the outside clamps installation.
12. Slide the outside clamps on the mounting forks and push up to the flange on the forks. Tighten the four mounting screws.
13. Reinstall the trapdoor linkage and re-enable the trapdoor.
14. With the trap door in the closed position, cycle the front and rear clamps making sure the clamps are closing completely without stalling or interference. If the either of the clamps are stalling, adjust the settings accordingly.
15. With the trap door in the closed position, disable the front and rear clamp. Push the clamps into the closed position and check for any interference. With no power to the clamps, they should move smoothly with no disturbance. Re-enable the front and rear clamps.
16. Adjust the gate channels (height and width) according to the size of fish being processed using the two downstream dials on the side of the channel.
17. With the clamps in the closed position, lower the clipper into the fin clipping window. Pull the clipper cable to nearly close the blade and anvil. Look down between the blade and anvil of the clipper and make sure it is centered over the area where the outside and the inside clamp pads meet. This alignment is pictured in the figure to the right with the red arrow. If the clipper is not centered, loosen the two screws that fasten the clipper to the clipper carrier, realign, and tighten.

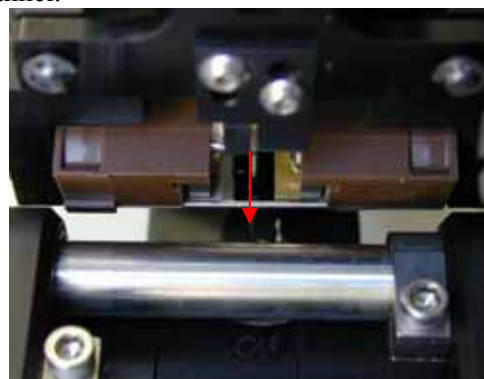

Preparing the Lines for Fin Clipping:

Before operating the marking and tagging lines in mark mode, the clippers should be checked to ensure the blade is sharp and that the anvil is in good condition. There should be approximately a 6-7mm space between the blade and anvil. If the blade and anvil are improperly spaced, the tension nuts on the cable are used for making necessary adjustments. The adjustment procedure is described below.

1. Loosen the lower nut and hold in position.
2. Use the upper nut to make necessary tension adjustments. Turning the nut clockwise increases the spacing between the blade and anvil and turning counter-clockwise decreases this spacing.
3. Tighten the lower nut to hold the new position.

A piece of electric tape (about 80mm long) can be folded in half and cut length wise to 5mm wide (cut the folded side off) and used to simulate a fin to test the clipper. Using the motor function on the handheld controller; cycle each clipper mechanism. If the blade is sharp and the clipper tension is set properly, the clipper will cut the tape with one cycle.

Observe the images on the computer after the first several fish and make sure that the fin is getting clipped properly. The first 10 fish should be caught and checked by hand to make sure the clips are not too deep.

If fish are not getting clipped properly or the clips appear too deep, the blade and/or anvil may need to be adjusted or replaced. The blade height adjuster is used to help make accurate adjustments. The blade height adjuster is equipped to make adjustments to both the large and small clipper. Following are step by step instructions and diagrams to make the necessary adjustments.

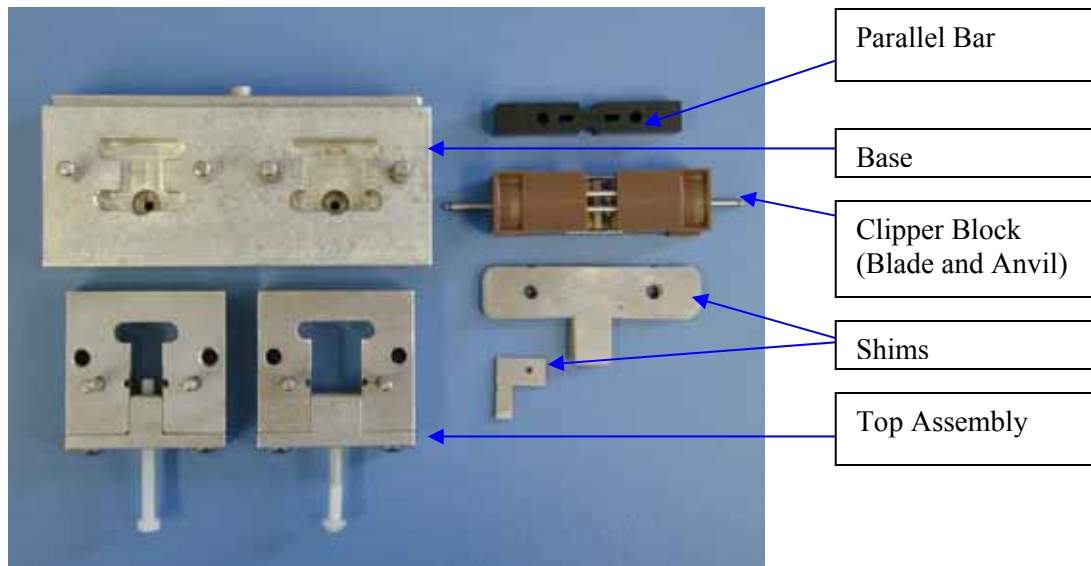

Figure 46: Clipper and Blade Height Adjustor Parts

★Clipper Block Removal

Prior to using the blade height adjuster, the clipper block must be removed from the line.

1. Loosen the tension lock nut to ease the removal of the clipper block.
2. Remove the two nylon lock nuts and bolts holding the clipper block assembly in the clipper assembly carrier.
3. Using a small bladed screwdriver, carefully remove the e-clip, nylon washer, and spherical bearing from each pivot shaft on the clipper.
4. Push the blade and anvil together and carefully remove the block from the clipper assembly. Make sure to place the clipper assembly in a position so that the plungers and springs are not lost.
5. Remove the inside spherical bearing off each pivot shaft of the clipper block.

★Using the Blade Height Adjuster

1. Place a new anvil and blade in each side of the clipper block. The blade should be placed in the block with the long bevel facing in the downward position.
2. Slide an anvil or a blade block into the base with anvil or blade installed with the setscrew finger tight.
3. Slide down the top assembly on the dowel pins over the blade or anvil block. There is one small shim located in each side of the top assembly that centers the blade or the anvil in the block. Caution must be taken when sliding the assembly down as not to bend the L-shaped shims. There are spare shims located on the back of the base if replacements are needed.
4. Place shims between plastic block and stainless steel knife holder bracket as required for proper height and tighten the plastic thumb screw with light force. Too much force will make removing shims difficult.
5. Small fish typically require four or five shims and larger fish typically require three or four shims.
6. Slide parallel bar down on pins over anvil or blade.
7. Apply downward pressure on either side of the parallel bar.
8. Tighten knife holder bracket setscrew while pressing down on parallel bar.
9. Loosen plastic thumb screw and remove parallel bar, shims, and top assembly.
10. Repeat process with mating piece of clipper block.
11. Slide the two sides of the clipper block together to make sure the blade and anvil hit each other square and that the blade is centered on the anvil. No light should be visible between the blade and anvil when in the closed position.



★Clipper Block Installation

Once the blade and anvil side of the clipper block have been properly adjusted, they may be re-installed on the line.

1. Place a spherical bearing on each pivot shaft of the clipper block.
2. Place the clipper block into the marker assembly.
3. Place another spherical bearing on the end of each pivot shaft followed by the small nylon washer. Secure each end with an e-clip.
4. Slide the clipper block assembly into the clipper assembly carrier, position the bolts through the holes, and hand-tighten the nylon lock nuts.
5. With the power off to the line, manually push the clamps into the closed position and move the marker assembly into the clamp window.
6. Using the cable to manually close the clipper assembly move the clipper side to side until the middle of the closed clamps are aligned with the center of the closed clipper.
7. Once centered, tighten the lock nuts and double check that nothing moved during the tightening process.
8. Using the tension nut adjust the tension of the clipper. Proper tension will leave a 6-7 mm gap between the blade and anvil in the open position.
9. Tighten the tension lock nut.
10. Using the handheld controller, cycle the clipper and ensure that it will effectively clip through a piece of doubled up electrical tape.

Preparing the Lines for Operation:

★Aligning the camera

The camera on each line should be aligned prior to operation. With each line in the ‘align’ mode, adjust the camera height so that the clamp edges, between the horizontal blue lines, are solid and straight as described in the marking and tagging software section. To accomplish this, the camera assembly may need to be adjusted vertically. Adjust the camera horizontally so the left and right clamp edges are clearly seen and do not interfere with the edge of the backlight. The camera lens focus should be adjusted to the far setting and the F-stop should be set just bright enough as not to see any glare in the live image.

★Calibrating the lines

There are three modes in which the lines may be calibrated:

1. Press the green button on the zenith of the line controller box.
2. Press the ‘Cal’ button on the handheld controller.
3. Press the ‘Calibrate’ button for each line on the line software.

Once the line has been successfully calibrated there are three ways to start processing fish:

1. Press the flashing green button on the zenith of the line controller box.
2. Press the ‘Run’ button on the handheld controller.
3. Press the ‘Start’ button for each line on the line software.

While the lines are processing fish, there are three ways to stop processing fish:

1. Press the solid green button on the zenith of the line controller box.
2. Press the 'Stop' button on the handheld controller.
3. Press the 'Stop' button for each line on the line software.

There are two lights on the zenith of the line control box which are used to indicate the mode of operation for each line. A solid red light indicates that the line has not been calibrated. A flashing red light indicates that the line has automatically shut down due to a reoccurring error. A solid green light indicates that the line is operating and a flashing green light indicates that the line is calibrated and ready to run but has not yet been started.

★Simulation Run

The lines should be run in simulation for a short time before processing fish. This gives the operator a chance to check the operation of the mechanisms and make adjustments prior to processing fish.

Place the line in Simulation mode in the 'Special' tab of the Configuration window or by pressing the 'Sim' key on the handheld. Calibrate each line and check to see that the calibration procedure is properly finding the edges of the clamp window and the fiducial of the marker.

The camera assembly can be removed and placed on the hanger once the line has been calibrated for the simulation run. This gives the operator a better view of the fish processing area. Things to look for during simulation are:

1. Gates: The gates should be opening and closing quickly and freely without sticking.
2. Holder operation: The front and rear clamps should operate smoothly without binding or stalling.
3. Marker XY operations: The movement of the marker should be smooth without chattering in either the X or Y direction. The blade assembly should move down the very edge of the front and the rear edges of the clamp window without touching the sides.
4. Trapdoor: The trapdoor stalling will likely be apparent by either not closing all the way or opening to a different position on consecutive cycles.

If all of these mechanisms operate properly, the marking and tagging line should be ready to process fish. If any problems occur during simulation, they will likely cause problems during normal operation and will need to be solved.

Production in the AutoFish Trailer

Processing Fish:

★Sorting Fish

To begin sorting fish, exit the sample mode and press the 'System Feed' button to begin delivering fish to the lines. There are several mechanisms with adjustments to assist the fish pump with a steady delivery of fish to the sorter VE.

In both the idle and high speed, there should be water traveling over the dewatering device. The high speed may need to be adjusted depending on the size of fish being processed. Large fish may require a higher speed to move them through the delivery pipe where small fish will move adequately at a lower speed.

The fish pump valve opens and closes at given intervals in cooperation with the pump speed to permit fish entry into the pump. The open and close time and position may be adjusted to help keep the density in the VE consistent.

As the first fish are being sorted, ensure that the head and the tail are being detected accurately. After several hundred fish are run through the sorter, observe the 'Performance' tab in the sorter data window and make certain that the multiples and unsafe holds below 4%.

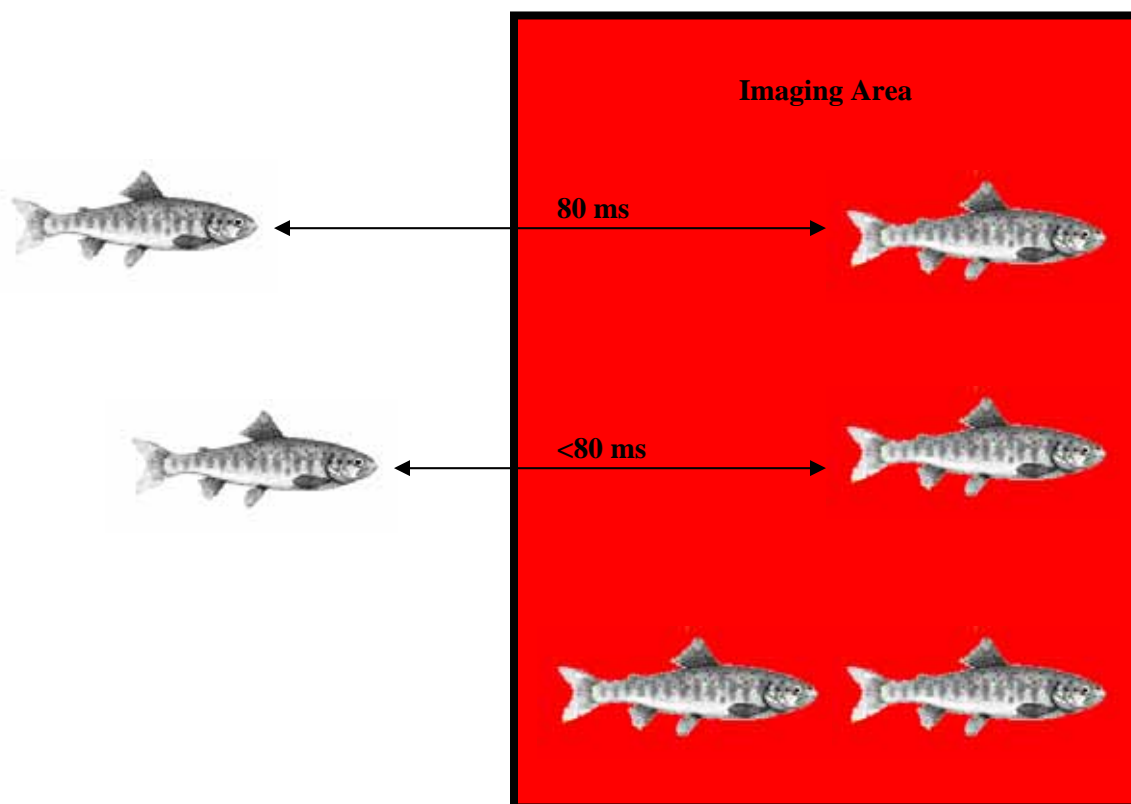

Figure 47: Spacing of fish within the imaging area of the sorter

In Figure 47, the top image illustrates two fish with the sufficient spacing of 80 milliseconds. These fish will both be measured and sent to the appropriate ports. The middle image pictures two fish with less than 80 milliseconds of spacing between. This will result in an unsafe hold and the second fish will be sent to the same port as the first. If the computer detects the unsafe scenario in time, both fish will be sent to the reject port. The third set of fish exemplifies a multiple and will also be sent to the reject port.

If the errors are high, make adjustments to the transition water, wires, and or water jets to improve sorter performance. If the recommended adjustments are not providing adequate separation and are resulting in a high number of unsafe holds and multiples, increase the pressure and the angle of the jets, close the wires of the aperture, and/or decrease the trigger sensor being used.

Adversely, if the throughput is low when using the recommended settings, decrease the pressure and the angle of the jets, open the wire aperture, and/or increase the trigger sensor number being used.

While sorting fish, closely monitor the percentage of shape errors. If the shape errors exceed 4%, the amount of transition water should be increased to make the backlight chute more comfortable. The rubber cover, just above the imaging area, can also be adjusted. If fish orientation is suffering, the backlight chute cover may be adjusted to either slightly sag into the chute or stretched tightly across.

★Marking Fish

Prior to processing fish, ensure that each marking and tagging line is set for the proper function being performed.

Once each line has received several sorted fish, start one line at a time to ensure proper operation. Lift the start gate and allow two or three fish into the gate channel. Hold the QCD diverter toward the front of the trailer as the fish are processed. Check the first several fish for clip quality and proper coded wire tag placement. For improper tag placement or clip quality issues, see the following section which details processing errors.

Once the clip quality and the tag placement are ensured, watch the fish flow through the entire system. Fish should travel smoothly through the gate channel and the clamps into the head mold with no hesitation. The water flow within the gate channel or the gate open position may need to be adjusted if the fish are sticking in the channel. The front and the rear clamps should be set so the fish travel quickly and smoothly throughout. If the clamps are open too far in the open position, the fish may fall over sideways and not reach the head mold. Adversely, if the clamps are too close in the open position, the fish may not make it in the clamps at all. Observe several fish being processed prior to making any changes to motor positions.

The nose sensitivity may be adjusted between 1 and 50. When the fish enters the head mold, the clamping process should begin immediately. If there is any delay in the clamping process, this number may need to be increased. Adversely, if the clamps are triggering prior to the fish entering the head mold, the sensitivity may need to be decreased. The sensor button on the handheld is used to enter the menu to make these changes.

When the clamps are in the closed position they should close completely without stalling. Check the errors on each line to ensure all of the motors are operating properly without stalling. If any of the mechanisms are stalling, see the troubleshooting section for potential solutions.

Once all of the lines are operating, perform a quality control check at the outlet to check the overall performance of the system.

★Coded Wire Tagging (CWT) Fish

When tagging, make certain that the MKIVs are set for the correct length of tags specified on the CWT spool. The CWT should be placed in the adipose or connective tissue within the snout as shown in Figure 48. Tag placement that is not completely within the target area can cause damage to the fish or result in poor tag retention.

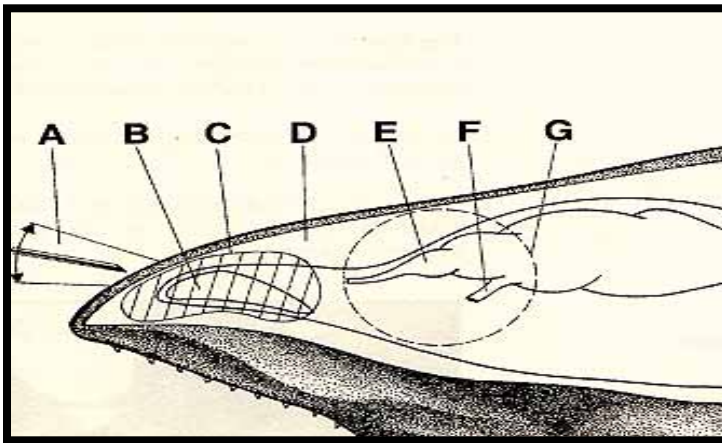

- A. Usual range of needle angle.
- B. Muscle, adipose, and fibrous tissue.
- C. Tag target area.
- D. Cartilage.
- E. Olfactory lobe and nerve.
- F. Optic nerve.
- G. Eye position.

Figure 48: Typical Tag Placement for Salmonids

Tag placement should be checked on each marking and tagging lines several times a day for the first day of tagging to insure proper placement. After the first two days and tag placement is set, it should be checked at least once a day.

★Initial Quality Control Checks (QC)

Quality control checks are done to assess the quality of the operation being performed on the fish that are exiting the trailer. Fish should be caught at the end of the outflow pipe, anesthetized, checked for the quality of clip, number of tagged and untagged, and overall general health.

When necessary, each line may be checked for quality independently by installing the isolation port as shown in Figure 49. This is necessary when the main QC check shows a problem and the cause is not immediately apparent to the operator. To install, stop line and remove the 3" flex

hose that connects the line to the 4" main line. Install the new plumbing on the back of the line and direct it into the spare reject bucket. Install the fish plug into the main line or leave the flex hose attached to the main line and direct in the upward position so fish do not escape. Start the line and all successfully processed fish will be diverted to this bucket.



Figure 49: Line Isolation Port Installed

Fish Processing Errors:

While processing fish, there are four error modes associated with the failure to process an individual fish; Find Fin Failure, Verify Mark Failure, Tag Failure, and Parolee. These four errors are described in the proceeding sections along with potential plans of action when failure modes reach the designated high.

★Find Fin Failure

In order to clip the adipose fin, the camera must first locate the fin. If this operation fails and the fin is not located, the clip is not attempted. If the Find Fin Failure rate exceeds 2% the marking and tagging line should be thoroughly examined.

Before troubleshooting any Find Fin problems ensure that all mechanisms on the line are functioning properly and not stalling. Here are some likely causes of a high percentage of Find Fin Failures:

1. After clamping the tail has come out of the rear clamps (high tail) and is moving in the imaging area preventing the computer from locating the adipose fin.
 - a. Belly lifters may be lifting the fish too much forcing the tail up and into the clamp window.
 - b. The clamps may be opened too far in the open position allowing excess room for the fish to move its tail up into the clamp window prior to processing.
 - c. Excessive water flow in the channel may force the tail out of the rear clamps into the clamp window.
 - d. The clamps may not be closing all the way and not properly holding the fish.
2. Clamps are closing and no fish back is visible in the find fin image.
 - a. Nose sensor sensitivity may need to be reduced.

- b. The clamps may not be closing all the way preventing the fish from popping up in the imaging area.
 - c. Check to see that the foam pads and belly lifters are properly installed.
- 3. Fish is moving during the Find Fin Imaging. If the fish is moving during the Find Fin Imaging ensure that the clamps are closing to the appropriate location so that the fish is being held securely.
- 4. Imaging.
 - a. The spinner, prism, or camera may be fogged or dirty preventing the computer from locating the adipose fin.
 - b. Excessive water flow in the clamps may interfere with the imaging system locating the adipose fin.
 - c. Check the last calibration images to be sure that all calibration criteria have been met.
 - d. Closely evaluate the Find Fin Images of the Find Fin Failures to determine if there is any anomaly preventing the adipose fin from being located.
 - e. Check the F-stop and focus settings on the camera.

It is recommended that after any change is made to the line camera, the imaging system be re-calibrated.

★Verify Mark Failures

Once the lines are operating be sure to closely monitor the clip quality of each line. If the quality control checks are yielding poor clip quality and/or the Verify Mark Failure percentage is greater than 3% the marking and tagging line should be thoroughly examined.

Be sure that all mechanisms are functioning properly and not stalling. Cycle the clipper with the handheld to ensure that it will cleanly cut through a small piece of (3mm) wide piece of electrical tape. Some possible causes of a line not clipping adipose fins or incompletely clipping adipose fins are:

1. Blade or anvil.
 - a. Check for worn or misaligned blade and anvil.
 - b. Blade tension may be set too high or too low. Proper spacing between the blade and anvil should be between 6 and 7mm.
 - c. The blade height may need to be adjusted.
 - d. Clipper is clipping too deep and it appears as though it is not removing the entire fin. Adjust blade height and reduce push down steps.
2. Clipper placement or movement.
 - a. Clipper is not centered between the clamps.
 - b. Clipper carrier shafts may need to be cleaned with alcohol and lubed with grease.
 - c. Clipper is not gambling properly.
 - d. Clipper is moving to the wrong position to clip the fin. This may be caused by too much water in the clamping area.
3. Marker movement.
 - a. The push down steps may need to be increased.
 - b. The Marker Y may have lost the correct home position.
 - c. The marker assembly may be twisted. Check the springs inside the control box for proper alignment.
4. Fish placement within the clamps.
 - a. Fish back is not properly arched. The belly lifters may need to be replaced.
 - b. Fish is not centered in the clamps. Check the foam products for proper placement.

★ Tag Failures

When the Tag Failure rate exceeds 1% and/or when performing quality control checks the initial tag loss is over 1%, tag placement should be checked immediately. If the tag placement is good, the following steps should be taken.

Isolate each line and check several fish for the presence of a tag. This isolated QC will indicate which line is causing problems and the necessary steps may be taken to solve the issue.

1. Check to make sure QCD gate is operating correctly.
2. Check to make sure that double fish are not getting through the channel.
3. Make sure the fish are getting held properly and that the clamps are not stalling.
4. Check the QCD threshold.

If upon examination the tag is not placed properly, the following steps may be taken.

1. If the tag is too deep or too shallow:
 - a. Check the 'Show' position to make sure the end of the wire is just visible in the center of the bevel of the needle.
 - b. Adjust head mold in or out to place the tag properly.
2. If the tag is too high or too low:
 - a. Check that the trap door is closing all the way.
 - b. Adjust the stop block on the trap door.
 - i. If the tag is too low move the stop block on the trap door down slightly (see Figure 50 below).
 - ii. If the tag is too high move the stop block on the trap door up slightly (see Figure 50 below).

It is helpful to make a pencil mark on the head mold for a reference point when making adjustments. Very small adjustments are usually adequate.

Adjusting the stop block on the trapdoor changes the angle at which the fish travels into the system as shown in Figure 50. This in turn changes the penetration point and the tag location.

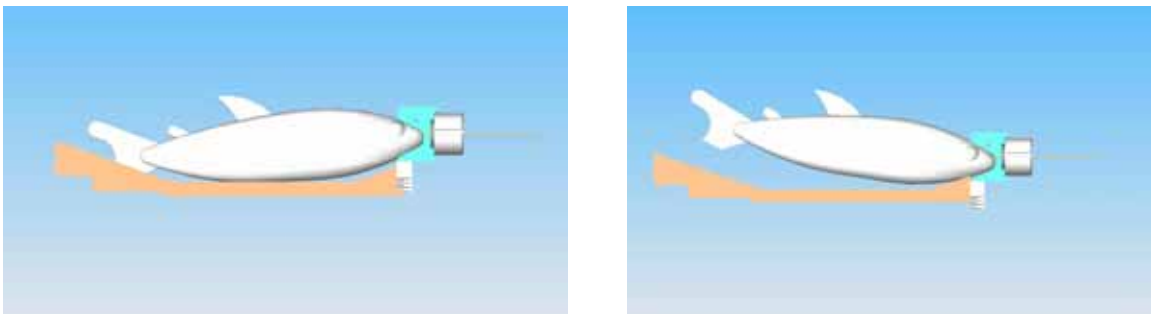

Figure 50: Needle Penetration in Reference to Tag Height

★Parolees

Once clip quality and tag placement have been evaluated, fish flow through the channel and clamps can be assessed. A good indication of fish flow through the line is the parolee percentage. If the percentage of paroles reaches 4%, the marking and tagging line should be thoroughly examined.

Paroled fish are diverted to the reject containment system and result in increased labor and an increased number of fish that need to be re-handled. Paroling a fish is also a very slow process and can dramatically slow the overall throughput of the trailer. Before troubleshooting any parolee problems, ensure that all mechanisms on the line are functioning properly and not stalling. The following are some likely causes of a high percentage of paroles.

1. Fish are moving slow through lower gate.
 - a. Ensure lower gate is opening sufficiently.
 - b. Check to be sure the lower gate home position is correct.
 - c. Check proper mechanical function of the lower gate.
 - d. Channel height and width may need to be adjusted.
2. Fish are moving slow in channel between lower gate and clamps.
 - a. Channel height and width may need to be adjusted.
 - b. Water flow to the channel may need to be adjusted.
3. Fish are getting stopped at the transition between the gate channel and rear clamps.
 - a. Rear clamps may be closed too far in the open position.
 - b. Water flow to the channel may need to be adjusted.
4. Fish are getting held up in the rear clamps.
 - a. Rear clamps may be closed too far in the open position.
 - b. Rear clamps may be open too far in the open position causing the fish to fall over in the rear clamps.
 - c. Water flow in the channel may need to be adjusted.
 - d. Ensure that the aluminum adapter plates and foam pads are properly installed on the clamps.
5. Fish are being delayed through the belly lifter area of the clamps.
 - a. Ensure the foam pads are properly installed on the clamps.
 - b. The placement of the belly lifters may be hindering fish flow.
 - c. Water flow to the channel may need to be adjusted.
 - d. The open position of the front and/or rear clamps may be closed too far.
6. Fish are being slowed through the front clamps.
 - a. Water flow in the channel may need to be adjusted.
 - b. Front clamps may be closed too far in the open position.
 - c. Front clamps may be too open in the open position, allowing the fish to move its head and preventing it from entering the head mold.
7. Fish are getting to the head mold and paroling.
 - a. Nose sensor sensitivity may need to be increased.
 - b. Be sure that the trapdoor is functioning properly and that the home position is correct.
 - c. Check for proper MKIV and trapdoor adjustment. An increased flat spot around the head hole may prevent the fish from completely entering the head mold.

Processing Fish from the Reject Containment System:

As fish are being processed, some fish will be rejected and sent to the reject containment system. Rejects consist of fish that have been paroled, received a poor clip, or did not receive a tag. Prior to reprocessing, rejects need to be anesthetized for safe handling. Depending on the marking and/or tagging function being performed rejects may have to be treated differently. The following pages show flow charts of how rejects should be handled.

Mark Only



Clip all rejects by hand
and send to the pond.

Use the 'Total' number from the batch report for total when in Mark Only mode.

Tag Only



Check all rejects for tags.

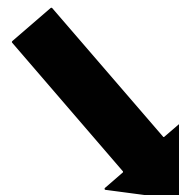
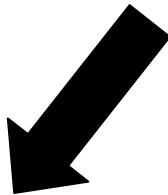

If the fish is tagged,
send it directly to the
pond.

If no tag is present,
the fish should be
reprocessed.



Return to the
sorter to
process.

Hand tag
and use
MKIV count
for hand
tagged total.

Use the 'Tagged' number from the batch report for total when in Tag Only mode.

When hand tagging, add the MKIV count to the 'Tagged' total from the batch report.

Mark and Tag

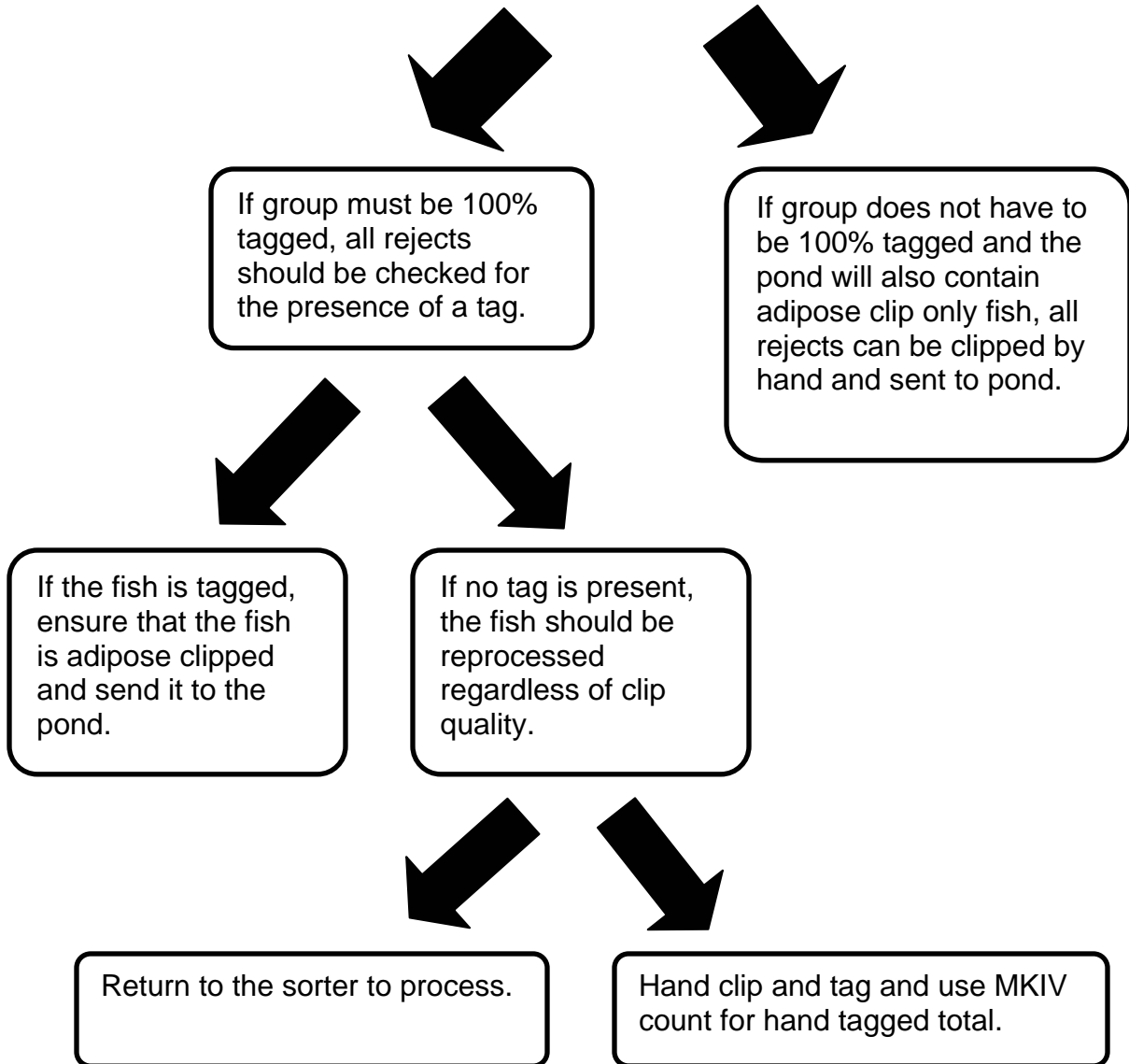

Use the 'Tagged' number from the batch for total when in Mark and Tag mode.

When hand tagging, add the MKIV count to the 'Tagged' total from the batch report.

To report the mark only fish, subtract the tagged number from the total number.

AutoFish Maintenance

Proper maintenance of the AutoFish system is critical for smooth operation.

Daily Maintenance:

1. At the end of each workday the marking and tagging lines should be thoroughly rinsed to remove silt and fin buildup. The camera is the only equipment that cannot be directly rinsed with the hose; even with the cover in place.
2. The under side of the adjustable gate channel walls are especially susceptible to silt accumulation. To avoid this, the hose should be directed through the small openings at the top of the gate channel top while working the width adjustment back and forth.
3. The Mark IV cutter, needle, and drive rollers should be cleaned at the end of every workday. The procedure is as follows:
 - a. Remove cutter and clean thoroughly using alcohol and a small brush. Store the pin and sleeve separated in an alcohol filled jar. Do not mix cutter parts as each pin is designed for a specific sleeve. Scotch Brite may be used to remove the corrosion from the cutter parts.
 - b. Clean the inside of the cutter block with alcohol and the brush.
 - c. Clean the needle and needle carrier with alcohol, paying particular attention to the area where the needle carrier and cutter block mate.
 - d. Clean the driver rollers with alcohol and a paper towel.
 - e. Leave the drive rollers disengaged when the injector is not in use.
 - f. Leave cover open to dry injector.
4. Turn off the air compressor and open drain valve to allow excess moisture to escape.
5. Turn on heaters and open windows slightly to allow moisture to escape.

Winter Daily Maintenance:

It is extremely important to be aware of cold weather conditions. Taking additional necessary precautions when shutting down the trailer will avoid damage from freezing.

1. If power or heat is not available open all valves so water can drain from the plumbing.
2. Remove the pump hose from both the trailer and the pump and drain water from hose. Always leave the pump submersed in water during freezing conditions as removal may damage the internal structure.
3. Drain water from the booster pumps, the fish pump, and the high pressure system plumbing.

Weekly Maintenance:

The weekly maintenance should be interpreted as a required procedure at the end of the workweek.

1. The shafts of the XY clipper table have a tendency to accumulate a black coating of debris and old grease. At least once a week (more if necessary) they should be thoroughly cleaned with alcohol and re-lubricated. Use only SuperLube grease to coat the shafts well and then move the marker carrier back and forth and up and down several times to distribute the grease

evenly (while the line is powered off). Then use a paper towel to wipe the shafts removing the excess grease leaving a very thin layer. Excess grease on the shafts may cause increased wear on the marker bearings.

2. Clean and lubricate the holder mechanism shafts as described above.
3. Apply some SuperLube grease to the height and width adjustment pinions (the ‘toothed’ shaft near the adjustment wheels) and move the mechanisms to distribute the grease.
4. Remove and clean all strainers. This includes the main strainer under the trough and the booster pump strainers. They may have to be done more often depending on the debris present in the water system.
5. Sorter cylinder life can be prolonged by oiling them on a weekly basis. A single drop of food grade air tool oil should be placed on each shaft and inside each air hose fitting.

Annual Maintenance:

This maintenance list should be performed on an annual basis in conjunction with the daily and weekly maintenance tasks.

★AutoFish Lines

1. Remove the shields, spinners, and spinner plates from the camera on each line. Clean with a soft cloth and replace any damaged parts.
2. Remove and clean the prism on each line with a 100% cotton cloth.
3. Check all screws for adequate tightness. Replace any damaged or stripped screws.
4. Remove top gate channel cover and clean gate channel. Check all components within the channel to ensure proper operation.
5. Check alignment of the gate channel exit with the clamping area and adjust if needed.
6. Clean and adjust channel gates.
7. Check for water intrusion in the control box and seal any leaks with RTV.
8. Check that clippers are in good working order. Remove and clean all clipper components and check belts, cables, couplers, and shafts for damage and proper tightness.
9. Check all holder shafts for stripped gears by pushing the shafts with the power on.
10. Check the home position of all nine mechanisms.
11. Check all cables and wires on and around the lines for wear or damage.
12. Disassemble each MKIV mount and clean and lubricate.
13. Drain all water from lines.
14. Inspect all cable connections.
15. Breakdown and clean solenoids.
16. Inspect flow meters, partial breakdown for cleaning.

★Adapter Plate Inventory

1. Check each set of plates for completeness.
2. Check that all head molds are securely attached to the head mold base.
3. Check and replace any stripped screws.

★Sorter

1. Clean the sorter mirrors with a 100% cotton cloth.
2. Inspect backlight chutes for possible leakage and/or bad LEDs.
3. Check all cylinders, wedges and mounts and replace if necessary.

4. Inspect and lubricate all air cylinders on diverter gate system.
5. The booster pump pressure tanks should be checked to ensure pressure is at 48 psi.
6. Check Booster Pump operation (noisy bearings).
7. Check condition of filters/strainers.
8. Inspect flow meters and perform partial breakdown for cleaning.
9. Breakdown and clean solenoids.
10. Check adjustable apertures for missing parts and bent wires.
11. Check Sorter frame, piping and adjustable mounts.
12. Breakdown, clean, and inspect diverters for proper operation.
13. Ensure distribution piping secured properly.
14. Check function of air compressor.
15. Drain all moisture from pneumatic system.

★Fish Lift

1. Check and adjust belt tension.
2. Ensure free operation of valve.
3. Clear pump of debris.
4. Inspect hose and fittings for any damage.
5. Open and clean VE camera enclosure, adjust if necessary.
6. Check and clean dewatering device.

★Trailer Shell and Components

1. Remove all items from drawers and cabinets. Clean and restock.
2. Check tool and spare parts inventory and restock.
3. Scrub inside and outside of trailer. Turn on heaters to dry trailer before storage.
4. Check power cords for defective sheaths.
5. Lube all tongue and stabilizer jacks.
6. Check all tires for defects, nails, or foreign items.
7. Check all tires for proper air pressure.
8. Fill propane bottles.
9. Occasionally the wire connections inside the cord body may become loose or worn. In either of these cases, the cord body may become hot. If the connectors are hot to the touch they need to be repaired. Before repairing, disconnect the cords from the hatchery power supply. Disassemble the cord body and remove approximately 1 foot of power cord and reattach the wires to the connector.

Disinfecting the AutoFish Trailer

Disinfecting Procedures:

The following protocol should be followed for disinfecting the AutoFish system and associated equipment. This will insure no pathogens or contaminants are passed from one hatchery to another.

1.7 gallons bleach
9 gallons distilled water
Safety equipment: rubber gloves, respirator and goggles
One 100 gallon fish transport tote

1. Extensively clean trailer before disinfecting. This includes: walls, cupboards, troughs, VEs, buckets, and fish channels on lines.
2. Run the floor drain hose to an area safe for disinfecting with bleach water. Ensure the water will not drain into ponds containing fish or directly into any other water source.
3. Remove the 4 inch discharge hose and place the tote below the outflows on the trailer to create a closed system.
4. Move the crowder up to the fish pump intake and place all loose submersible equipment in the trough behind the crowder.
5. Open all valves and flow meters so bleach water can flow through.
6. Fill the holding trough, back trough, and tote with water. Place the main water pump in the tote.
7. Turn on the main pump to circulate the water. Check that the water is equalized. Ensure that the tote does not run out of water. Water may need to be added to equalize the system prior to adding the bleach.
8. Double check that no bleach water can drain into a pond or water source.
9. Distribute 1.7 gallons of household bleach between the main trough, back trough, and tote.
10. Place the marking and tagging software in disinfect mode to activate fin washers and fish ejection solenoids.
11. Place the sorter software in disinfect mode to activate the water jet solenoids.
12. Turn on the fish pump and press the 'System Feed' button.
13. Open the sorter setup menu in the sorter software and click on the 'Test Ports' button to activate both diverters. Test ports for 30 seconds to allow water to divert through all of the distribution lines.
14. Press the 'Show' button on the MKIVs and step the diverter gate back and forth to disinfect both sides of the diverter outflow.
15. Rinse the inside of the trailer; spray walls, floor, outside of lines, outside of trough, and hand processing area.
16. Once disinfection is complete, turn the main pump, booster pumps, and fish pump off.
17. Rinse each marking and tagging line thoroughly with 1 gallon of distilled water (must be pathogen free) including: gates, clippers, clamps, head mold, and MKIV.
18. Rinse the sorter and sorter cylinders with 1 gallon of distilled water.
19. To disinfect the MKIVs use a 200 ppm sodium hypochlorite (bleach):
 - a. Wipe the exterior of the machines with the chlorine solution.
 - b. Remove the head mold which should already have been disinfected.
 - c. Remove the needle, needle carrier, clamping nut and cutter.
 - d. Disassemble the needle carrier and the cutter pin and sleeve.

- e. Immerse these parts into a container of chlorine disinfectant.
 - f. Spray alcohol onto the exposed interior surfaces taking care to include the drive rollers, wire guides, tension springs, drive roller latch, hinges, lower drive roller arm, and all screws.
 - g. Using alcohol wetted Q-tips, thoroughly clean all surfaces and orifices/tubes of the machines.
 - h. Rinse the soaking injector parts with distilled water and place in a container of alcohol.
 - i. Spray alcohol through both of the wire guides until a steady flow reaches the opposite end.
 - j. Release the tension on the drive rollers and leave the case open to allow the injector to dry.
20. Disinfect all clamps that were used during the marking and/or tagging operation. A 1:100 solution of PVP Iodine to distilled water (3 TBSP: 1 gallon) is recommended for disinfecting clamps. The clamps must disinfect for 1 hour and then be rinsed with distilled water.
21. All hoses, hose stands, stairs, power cords, and any other accessories outside the trailer should be disinfected in the tote before loading into the trailer.

Preparing the AutoFish Trailer for Transport

1. Shut down both computers.
2. Turn off UPS.
3. Open drain valve on fish pump.
4. Open drain valves at the rear of the trailer on the high pressure lines.
5. Remove drain plugs from booster pumps and main strainer.
6. Mount cameras on lines and secure using zip ties.
7. Secure MKIVs in the downward position on lines.
8. Remove all accessories from desktop and stow.
9. Secure touch screens.
10. Load all hoses.
11. Load all power cords. During the winter leave the trailer plugged in until the move to avoid freezing.
12. Raise rear jack stands.
13. Load all wood blocking, hose stands, and net pens.
14. Load all steps.
15. Secure doors.

Emergency Procedures

Loss of Power and/or Water:

In the case that the AutoFish trailer loses power and/or water during operation, the following procedures should be followed:

1. Remove fish from the sorter and line VEs.
2. Remove fish from the gate channels (May have to dump buckets of water through the channel).
3. Pull the pin on the fish pump valve actuator.
4. Remove fish from the troughs.
5. Remove hose for the dewatering device and lower to remove the fish from the fish pump.
6. Process fish from reject containment systems.
7. Shut down both computers.
8. Turn off UPS.

Always know where the hatchery's main distribution panel is located. The problem may be as simple as a tripped breaker and may quickly be corrected.

AutoFish Troubleshooting

Listed below are some common problems, possible causes, and potential solutions. Since in some cases, there may be more than one cause or solution to a specific problem, simply observing the abnormal operation and identifying the specific problems associated with it may be of great importance in reaching a solution.

Trailer will not Power Up:

1. **Problem area:** Hatchery electrical breaker.

Solution: Check the hatchery outlet breaker. Switch on the hatchery breaker if it is off.

2. **Problem area:** Incorrect power.

Solution: Check the volt meter located in the front of the trailer to ensure that the trailer is receiving proper voltage. If the voltage coming into the trailer is incorrect, the voltage sensing relays will not allow the trailer to power up.

Computer:

1. **Problem area:** Computer will not turn on.

Solution: Check that the UPS is on. The computer will not turn on unless the UPS is on and functioning properly.

Solution: Check the toggle power switch and button power switch located on the back of the computer. If the computer is not powered on (when the computer is not powered on there is no audible fan sound coming from the computer) it is important to check both the power switches on the computer.

2. **Problem area:** Computer powers on but nothing shows on the screen.

Solution: If the computer powers up but the software does not come up, the circuit boards inside the computer may need to be re-seated.

Touch-screen:

1. **Problem area:** Touch-screen does not turn on.

Solution: Make sure that the power to the touch screen is on.

Solution: Check that the yellow power connection on the bottom of the screen is properly connected.

2. **Problem area:** Touch-screen powers on with computer but immediately fades out to gray.

Solution: Check that the yellow video connection on the bottom of the screen is properly connected.

Solution: The touch-screen may need to be replaced. Switch the video cables with another monitor. If nothing comes up the touch-screen will need to be replaced.

3. Problem area: Pointer does not go exactly where the screen is touched.

Solution: The touch-screen needs to be re-calibrated. To calibrate the touch-screen, go to the 'Start' button, 'Programs', and then follow the directions in 'UPDD Device'.

4. Problem area: Right monitor fails.

Solution: Right monitor must be replaced. Until the monitor can be replaced the marking and tagging software can be run from one monitor. To move all marking and tagging software to the left monitor follow the preceding steps:

- a. Press the 'Start' button in the bottom left hand corner of the screen.
- b. Press the 'Run' option in the Start menu.
- c. Type in regedit in the Run window and press the 'OK' button.
- d. In the registry expand the branch HKEY_CURRENT_USER\Software\NMT, and then open the folder named MaTS.
- e. Double click on the 'Dual-Screen' option and change it to 0 (False).

All the line applications will now be displayed on the left monitor. The windows may need to be moved around in order to view all pertinent information. It also may be necessary to use the mouse on the keyboard, rather than the touch-screen option, to navigate through the software.

5. Problem area: Left monitor fails.

Solution: Left monitor must be replaced. Until the monitor can be replaced the marking and tagging software can be run from one monitor. To move all marking and tagging software to the right monitor follow the preceding steps:

- a. Remove and exchange the 'Video' cables from the bottom of each of the touch-screens.
- b. Press the 'Start' button in the bottom left hand corner of the screen.
- c. Press the 'Run' option in the Start menu.
- d. Type in regedit in the Run window and press the 'OK' button.
- e. In the registry expand the branch HKEY_CURRENT_USER\Software\NMT, and then open the folder named MaTS.
- f. Double click on the 'Dual-Screen' option and change it to 0 (False).

All the line applications will now be displayed on the right monitor. The windows may need to be moved around in order to view all pertinent information. It also may be necessary to use the mouse on the keyboard, rather than the touch-screen option, to navigate through the software.

Booster Pumps:

1. **Problem area:** Booster pump will not turn on.

Solution: Breaker. The breaker in the power distribution panel may need to be turned on.

Solution: The yellow reset button, located on the pump, may need to be engaged.

2. **Problem area:** Booster pump is slowly losing pressure.

Solution: Dirty pump filters. Clean the inline filter and the intake filter for the booster pump.

3. **Problem area:** Booster pump runs at very low pressure.

Solution: The booster pump needs to be primed.

Solution: Bypass valve to lines is open. The pressure line for the marking and tagging lines has a bypass that must be closed for the booster pump to provide adequate pressure.

4. **Problem area:** Booster pump starts up, does not build up pressure, and then quickly shuts off.

Solution: Flow meters to the transitions are closed. If the booster pump outflow has no place to go the pump will shut down.

Solution: The booster pump needs to be primed.

Solution: Drain plug. Check to see that the drain plug is installed on the pump.

Fish Valve:

1. **Problem area:** Fish valve makes grinding noise, moves erratically, and loses home position.

Solution: Debris or fish build-up on top of the valve. If water flow through the valve is restricted, the valve will make a grinding noise, stall, and then lose home. Clear any debris from the top of the valve and re-home. If fish are building up on the valve causing it stall, make sure that the water level in the trough is maximized and that the fish are not over crowded.

2. **Problem area:** Fish valve is not moving.

Solution: Ensure that the pin that attaches the valve to the actuator is in place.

Solution: Power loss. If there was power loss to the trailer, the sorter software will have to be shut down and re-started to regain control of the fish valve. Often time the valve will also have to be re-homed following a power loss.

3. **Problem area:** Too many or not enough fish in the sorter VE.

Solution: The open and closed position and/or the open time and closed time need to be adjusted in the sorter software, according to the size and behavior of the fish.

Fish Pump:

1. Problem area: Fish pump is operating but little water is moving over the de-watering device or the fish are moving slow through the transfer pipe.

Solution: The pump speeds may need to be increased. If no water is moving over the de-watering device while in idle, the idle speed should be increased slightly. If the fish are moving slow and lingering in the transfer pipe, the high speed should be increased slightly.

2. Problem area: Fish are moving through the transfer pipe with excessive speed.

Solution: Pump high speed. The high speed of the pump should be decreased slightly so the fish move through the transfer pipe at a comfortable speed.

Solution: Pressure sensor. If the pump will not respond to changes made to the pump speed, the pressure sensor may need to be replaced. Contact NMT for pressure sensor problems.

3. Problem area: Fish pump is overloading the sorter VE.

Solution: Pump high speed. The high speed of the pump should be decreased slightly so the fish move through the transfer pipe at a comfortable speed and do not overload the VE.

Solution: Pressure sensor. If the pump will not respond to changes made to the pump speed, the pressure sensor may need to be replaced. Contact NMT regarding pressure sensor problems.

Solution: Fish Valve. The fish valve open settings may need to be changed; see the fish valve section above.

Solution: VE imaging. Evaluate the VE image and make sure that all settings are correct.

4. Problem area: Fish pump will not operate.

Solution: Power switch. The power switch, located on the front wall of the trailer, must be on in order for the fish pump to operate.

Solution: Pressure sensor. If the pump tries to ramp up to speed and then immediately stops, the pressure sensor may need to be replaced. Contact NMT regarding pressure sensor problems.

Solution: Overload. If the pump controller, located on the front wall of the trailer, reads 'OL1', the pump is in overload mode. This is usually due to a foreign object or debris preventing the pump impeller from turning. Contact NMT regarding pump failure due to overload.

5. Problem area: Fish pump is in emergency mode.

Solution: Debris or fish build-up on top of the valve. If water flow through the valve is restricted, the pump will go into emergency mode trying to clear fish from the top of the valve. Clear any debris from the top of the valve. If fish are building up on the valve causing the pump to go into emergency mode, make sure that the water level in the trough is maximized and that the fish are not over crowded.

Sorter:

1. **Problem area:** Loss of air pressure in the sorter.

Solution: Air compressor. Check the air compressor to make sure it is functioning properly and that the pressure release valve is in the closed position.

Solution: Damaged airlines or fittings. Inspect all airlines and fittings for damage and leaks.

2. **Problem area:** Loss of pressure to jets and transition.

Solution: Solenoid clogged. Remove solenoid and clean assembly as described in the MKIV manual.

Solution: Dirty pump filters. Clean the inline filter and the intake filter for the sorter booster pump.

Solution: Booster pump is not functioning properly. Pump may need to be primed.

3. **Problem area:** Back light chute does not light up or flickers.

Solution: Water intrusion. Water has intruded into the back light chute. Remove the circuit board and remove corrosion with a toothbrush and dish soap and dry completely before re-installing.

4. **Problem area:** Fish will not exit sorter VE.

Solution: Water level in the VE may need to be adjusted. The water level should be adjusted to just above the dorsal fin of the fish.

Solution: Level of the entire VE. The VE may need to be leveled (front to rear). If the front of the VE is too high, there may not be enough water at the exit of the VE and the fish will have trouble exiting.

Solution: Too much water in the transition. Turn the water pressure down so the fish can move through the transition area.

Solution: Wire aperture. The set of wires in the aperture may need to be adjusted to a more open position to allow the fish to move through.

Solution: Aperture roof. The roof between the wires may need to be raised to allow fish to pass through.

Solution: Water jet aperture. The jets angle and pressure may need to be adjusted. When processing large fish, the jet angle may need to be opened in order to allow for the larger fish to move through the system. When processing small fish, the jet pressure may need to be reduced to allow smaller fish to move through the system.

5. **Problem area:** Fish not being measured properly.

Solution: If the fish is being measured long, check the images for unnecessary water turbulence or water spots on the mirrors or channels.

Solution: Gradient threshold. Increasing this number makes the system less sensitive to 'noise' in the image but also makes the system less sensitive to detecting the edge of translucent tails. When this number is too high, fish may be measured at their peduncles. When this number is too low, fish may be measured at some anomaly in the image beyond the edge of the tail. Adjusting this setting may be helpful if either of the above situations occur.

Solution: Check to be sure the focus and F-stop settings are adjusted properly. If the image is too light or dark and/or is not in focus, the fish will not be measured properly. After any adjustments are made to the sorter camera, the sorter background should be calibrated.

6. Problem area: High number of unsafe holds, multiples, and/or miss-sorts.

Solution: Review images to determine if the fish are being measured properly. If the fish is not being measured correctly, check the items listed above.

Solution: Water flow. Adjust water flow in the transition until fish are straight and images are clear of turbulence.

Solution: Wire aperture. The set of wires in the aperture may need to be adjusted to a closer position to increase separation between fish.

Solution: Aperture roof. The roof between the wires may need to be lowered to help keep fish separated upon exit.

Solution: Water jet aperture. The jet angle and pressure may need to be adjusted. When processing large fish (45/# to 20/#), the three-hole jets should be used to help keep individuals separated. When processing smaller fish (250/# - 65/#), the two-hole jets should be installed. The jet angle will also need to be adjusted to help create adequate separation between individuals. The jet pressure may also be increased to aid in separation.

Solution: Trigger Sensor. The trigger sensor number used may need to be adjusted. Sensor #1 should be used for small fish and sensor #2 and #3 should be used for larger fish.

Solution: Diverter safety margin. Ensure that the diverter safety margin is set at 80. When the safety margin is increased, the system becomes less aggressive which may result in more unsafe holds.

7. Problem area: High percentage of out of size rejects during sorting.

Solution: Size distribution. Make sure that the sorter setup covers the whole size distribution and that all sizes are back to back with no gaps. Any fish that are not accounted for in the setup will be rejected.

Solution: If one of the ports is turned off and there is no other same size port, the fish will be rejected as an out of size reject.

8. Problem area: High percentage of shape errors.

Solution: Transition water. The transition water may need to be increased, to make the fish more comfortable traveling through the imaging area.

Solution: Rubber flap. Adjust the rubber flap above the imaging area to either sag into the back light chute or pull it tight so it is clear of the back light chute.

9. Problem area: Low throughput.

Solution: Wire aperture. The set of wires in the aperture may need to be adjusted to a more open position to allow the fish to travel easier through the aperture.

Solution: Aperture roof. The roof between the wires may need to be raised to allow the fish to travel easier through the aperture.

Solution: Water jet aperture. The jets angle and pressure may need to be adjusted. The jet angle and pressure should be decrease to allow the fish to travel easier through the aperture.

Solution: Trigger Sensor. The trigger sensor number used may need to be adjusted. Sensor #1 should be used for small fish and sensor #2 and #3 should be used for larger fish.

Marking and Tagging Line VE:

1. Problem area: Fish will not exit VE.

Solution: Water level in the VE may need to be adjusted. The water level should be adjusted to just above the dorsal fin of the fish.

Solution: Level of the entire VE. The VE may need to be leveled (front to rear). If the front of the VE is too high, there may not be enough water at the exit of the VE and the fish will have trouble exiting.

Gate Channel:

1. Problem area: Difficult to adjust.

Solution: Clean and lubricate. Clean the height and width adjustment pinions (the ‘toothed’ shafts near the adjustment wheels) with alcohol and apply some super lube grease. Move the mechanisms to distribute the grease.

2. Problem area: Fish moving slowly through gate channel.

Solution: Improper channel adjustment. Channel height and width must be adjusted to accommodate the particular size of fish.

Solution: Poor sorter performance. If fish are poorly sorted, it will be more difficult to maintain proper channel adjustment and avoid fish flow problems. Check the sorter to ensure proper sorting.

Solution: Fish entering the channel backwards. Decrease the density in the VE, so that fish will not be forced out backwards. Adjusting the level of the VE, to shallow the water at the exit, will aid in proper fish orientation.

Solution: Gate mechanism operation. Ensure that the gate is functioning and set up properly. Check that the open and close position of the gate is adequate.

Solution: Improper water flow. Change the water within the channel by adjusting the three flow valves on the base of the line. Remove the water lines from the channel to visually inspect water flow when making adjustments.

Solution: Fish are not properly starved. Ideally, the fish need to be off feed for at least 24 hours before processing, as fed fish may create problems in the gate channel area.

Gates:

1. **Problem area:** Fish moving slowly through upper or lower gate.

Solution: Gate is set up incorrectly. The driven crank should be vertical relative to the side of the gate when the gate is in closed position.

Solution: Incorrect gate home position. The drive arm for both gates should be parallel with the angle of the side of the line controller box when in the home position.

Solution: Improper spring tension. Larger fish may be able to push through the upper gate and move slowly through lower gate. The spring tension can be tightened in the software or with the handheld by adjusting the gate closed positions into the negative numbers.

Solution: Upper gate close sensor. The upper gate may need to be open for longer to prevent the fish from slowing through the upper gate. Upper gate close sensor is adjusted in the software or with the handheld controller.

2. **Problem area:** Gate not closing properly.

Solution: Gate shafts dragging on gate channel bottom. Remove gate from channel and adjust and/or tighten the small screws that hold the roller shafts in the lever arms.

Solution: Springs on the gate are worn out. Replace tension springs.

Clamping Area:

1. **Problem area:** Fish moving slow through the clamping area.

Solution: Improper water flow. Change the water within the channel by adjusting the three flow valves on the base of the line.

Solution: Foam pads. Check that the foam pads are properly installed on the clamps.

Solution: Clamps too narrow. Front and/or rear clamps are too close together in the open position and the fish is not able to travel through to the head mold. The open clamp position needs to be increased in the software settings.

Solution: Clamps too wide. Front and/or rear clamps are too far open in the open position. Fish may turn sideways and will not reach the head mold. The open clamp position may need to be decreased in the software settings.

2. **Problem area:** Clamps are not closing properly or stalling.

Solution: Mechanical conflict. Make sure that the clamps and the trap door are properly installed. With the trapdoor closed and the line off, close the clamps by hand. The clamps should close completely with no interference. If they do not close properly, look for mechanical interference.

Solution: Incorrect settings. The clamps can be set up to close too far, which compresses the foam and gives the foam a spring force with which to push the clamps open causing stalling. This is often visible and appears as if the clamps are “bouncing” back open.

Solution: Broken holder mechanism. To test for this, turn the power to the line off, hold the home sensor flag with one hand, and move the shafts with the other. If the shafts move without moving the flag, the holder mechanism is damaged. Contact NMT for holder mechanism problems.

Solution: Dirty shafts. The adapter plates should smoothly close completely by hand when the power is off. Clean the shafts with alcohol and apply a thin coat of superlube.

Marker X:

1. **Problem area:** Marker X movement is inconsistent.

Solution: Marker X shafts are dirty. The marker X shafts will occasionally acquire a build up on them, causing the movement of the marker erratic. Clean the shafts with alcohol and apply a thin coat of superlube.

Solution: Marker X drive belt loose. If the tension on the drive belt for the marker X is loose, it should be tightened using the slotted adjuster located on the upstream pulley.

2. **Problem area:** Marker X is not moving to the appropriate location.

Solution: Marker X home position is incorrect. Change to the appropriate home position and re-calibrate the line with imaging.

Solution: Calibration. Check the calibration images to be sure that the line has met all the calibration criteria.

Solution: Imaging. Check the alignment and setting of the camera to be sure that the computer is able to find the edge of the clamps.

Marker Y:

1. **Problem area:** Marker Y movement is inconsistent.

Solution: Marker Y shafts are dirty. The marker Y shafts will occasionally acquire a build up on them, causing the movement of the marker erratic. Clean the shafts with alcohol and apply a thin coat of superlube.

Solution: Marker Y drive belt loose. If the tension on the drive belt for the marker Y is loose, it should be tightened using the slotted adjuster located on the bottom pulley.

2. **Problem area:** Marker Y is not moving to the appropriate location.

Solution: Marker Y home position is incorrect. Change to the appropriate home position and re-calibrate the line with imaging.

Solution: Calibration. Check the calibration images to be sure that the line has met all the calibration criteria.

Solution: Imaging. Check the alignment and setting of the camera to be sure that the computer is able to find the edge of the clamps.

Clipper:

1. **Problem area:** Clipper will not clip electrical tape or adipose fins.

Solution: Check for worn or miss-aligned blade and anvil. Replace worn parts and/or realign the blade and anvil with the blade height adjuster.

Solution: Blade tension set too high or too low. The blade and anvil should be approximately 6-7mm apart in the open position.

- 2. Problem area:** Clipper has erratic movement when closing resulting in clipper stalling.

Solution: Blade tension set too high. The blade and anvil should be approximately 6-7mm apart in the open position.

- 3. Problem area:** Clipper is clipping too deep

Solution: Blade height adjustment. The blade cutting depth relative to the clipper head is adjustable. This adjustment should be made only if the clipper is consistently clipping too deep or too shallow.

Solution: Push down steps. The clipper is designed to push down on the fish back to ensure proper clipping depth and may be adjusted in the line software.

Trapdoor:

- 1. Problem area:** Trapdoor is stalling.

Solution: Trapdoor home position is incorrect. Proper positioning is best measured using the shaft in the spring linkage of the trap door. This shaft should be centered in the spring linkage when in the home and/or closed position.

Solution: Trapdoor interference with the clamps. Ensure that when the clamps are in the closed position they do not interfere with the trapdoor.

Solution: Trapdoor interference with the head mold. The trapdoor should be pushed all the way back in the trapdoor mount to ensure that it does not hit the head mold.

High Percentage of Find Fin Failures:

- 1. Problem area:** After clamping, the tail has come out of the rear clamps (high tail) and is moving in the imaging area preventing the computer from locating the adipose fin.

Solution: Belly lifters may be lifting the fish too much forcing the tail up and into the clamp window.

Solution: The clamps may be opened too far in the open position allowing excess room for the tail to move into the clamp window.

Solution: Excessive water flow in the channel may force the tail out of the rear clamps into the clamp window.

Solution: The clamps may not be closing completely and not properly holding the fish.

- 2. Problem area:** Clamps are closing and no fish back is visible in the find fin image.

Solution: Nose sensor sensitivity may need to be decreased.

Solution: The clamps may not be closing all the way preventing the fish from popping up in the imaging area.

Solution: Check to see that the foam pads and belly lifters are properly installed.

- 3. Problem area:** Fish is moving during the find fin imaging.

Solution: If the fish is moving during the find fin imaging ensure that the clamps are closing to the appropriate location so that the fish is being held firmly.

4. Problem area: Imaging problems.

Solution: The spinner, prism, or camera may be fogged or dirty preventing the computer from locating the adipose fin.

Solution: Excessive water flow in the clamps may interfere with the imaging system locating the adipose fin.

Solution: Check the last calibration images to be sure that all calibration criteria have been met.

Solution: Closely evaluate the Find Fin images of the Find Fin Failures to determine if there is an anomaly preventing the adipose fin from being imaged.

Solution: Check the F-stop and focus settings on the camera.

High Percentage of Verify Mark Failures (Insufficient Fin Removal):

1. Problem area: Clipper problems.

Solution: Check for worn or miss-aligned blade and anvil.

Solution: Blade tension set too high or too low. The blade and anvil should be approximately 6-7mm apart in the open position.

Solution: Clipper not centered. The clipper should be centered between the clamps.

Solution: Clipper shafts may need to be cleaned. Clean shafts with alcohol and apply a thin coat of superlube.

Solution: Blade height adjustment. Blade height may need to be adjusted slightly.

Solution: Push down steps. The clipper is designed to push down on the fish's back to ensure proper clipping pressure.

Solution: Clipper gimbaling. Ensure that the clipper gimbals properly.

Solution: Clipping too deep. The line may be clipping too deep and just appear as though it is not completely clipping the fin. Adjust blade height and reduce push down steps.

Solution: Clipper is moving to the wrong position to clip the fin. Too much water in the clamp area can cause imaging problems. Check the calibration image or recalibrate the imaging system.

2. Problem area: Marker assembly.

Solution: Marker Y. Marker Y may have lost the correct home position.

Solution: Marker Assembly twisted. The springs on the clipper cable inside the control box should be checked for proper alignment.

3. Problem area: Clamping area.

Solution: Fish back not properly arched. The belly lifter pads should create an arch in the fish's back. This causes the adipose fin to stand up on the fishes back.

Solution: Fish not centered in the clamps. If the foam pads and/or belly lifters are not installed uniformly on both the inside and the outside, the fish may be positioned incorrectly in the clamps.

High Percentage of Tag Failures:

1. **Problem area:** Tag placement.

Solution: Adjust the tag placement according to the tag placement section in this manual.

2. **Problem area:** Clamping area.

Solution: Fish not getting held properly. Be sure that the clamps are closing completely and not stalling. Adjustments to the clamps can be made in the software or with the handheld controller.

3. **Problem area:** QCD threshold.

Solution: Reduce the QCD threshold in the MKIV adjustment menu.

High Percentage of Parolees:

1. **Problem area:** Fish are moving slow through lower gate.

Solution: Ensure lower gate is opening far enough.

Solution: Check to be sure the lower gate home position is correct. The drive arm for the lower gate should be parallel with the angle of the side of the line controller box when in the home position.

Solution: Check proper mechanical function of the lower gate.

Solution: Channel height and width may need to be adjusted.

2. **Problem area:** Fish are moving slow in channel between lower gate and clamps.

Solution: Channel height and width may need to be adjusted.

Solution: Water flow to the channel may need to be adjusted.

3. **Problem area:** Fish are slowing at the transition between the gate channel and rear clamps.

Solution: Rear clamps may be closed too far in the open position.

Solution: Water flow to the channel may need to be adjusted.

Solution: Ensure that the aluminum adapter plates and the foam pads are properly installed on the clamps.

4. **Problem area:** Fish are getting held up in the rear clamps.

Solution: Rear clamps may be closed too far in the open position.

Solution: Rear clamps may be open too far in the open position causing the fish to fall over in the rear clamps.

Solution: Water flow in the channel may need to be adjusted.

Solution: Ensure that the aluminum adapter plates and foam pads are properly installed on the clamps.

5. **Problem area:** Fish are being delayed through the belly lifter area of the clamps.

Solution: Ensure the foam pads are properly installed on the clamps.

Solution: The placement of the belly lifters may be hindering fish flow.

Solution: Water flow to the channel may need to be adjusted.

Solution: The open position of the front and/or rear clamps may be closed too far.

6. Problem area: Fish are being slowed when traveling through the front clamps.

Solution: Water flow in the channel may need to be adjusted.

Solution: Front clamps may be closed too far in the open position.

Solution: Front clamps may be too opened in the open position, preventing the fish from entering the head mold.

7. Problem area: Fish are reaching the head mold and paroling.

Solution: Nose sensor sensitivity may need to be increased.

Solution: Be sure that the trapdoor is functioning properly and that the home position is correct.

Solution: Check for proper MKIV and trapdoor adjustment. An increased flat spot around the head hole may prevent the fish from completely entering the head mold.

Marking and tagging line is calibrated but will not start:

1. Problem area: MKIV.

Solution: MKIV state. Push the main display button on the display screen of the MKIV so the display shows the number of injections.

Solution: MKIV. Push the tag button on the MKIV twice and start the line.

Marking and tagging line will not calibrate:

1. Problem area: Imaging errors during calibration.

Solution: Imaging system cannot find the chevron within the fiducial. Water needs to be extracted from the fiducial to ensure a clear visual path for calibration.

Solution: Imaging system cannot find the left edge of the fiducial or either edge of the clamp window. Camera horizontal position needs to be adjusted in order to calibrate the vision system.

Solution: Imaging system cannot find the left edge of the fiducial. Water needs to be extracted from the upper surface of the clipper block to ensure a clear visual path for calibration.

Solution: Imaging system cannot find the top of the chevron within the fiducial. Camera vertical position needs to be adjusted in order to calibrate the marker.

Solution: Clamp edges or fiducial are dark or blurry in calibration images. The F-stop and/or focus needs to be adjusted in order to create a sharp and clear visual path for calibration.

2. **Problem area:** Clamp image does not match configuration error.

Solution: Check that line software size settings match the current clamps installed on the line.

Solution: Camera needs to be adjusted to match the current clamps configuration.

3. **Problem area:** Sensor errors during calibration.

Solution: Nose sensor calibration error. If the nose sensor is set to auto calibrate mode, the line may not calibrate and need to be set to manual calibrate mode.

Solution: Nose sensor calibration error. If above solution is not successful, the nose sensor may need to be replaced.

4. **Problem area:** Motor homing or offline error during calibration.

Solution: Motor homing error may signify that particular motor is disabled and needs to be re-enabled prior to calibration.

Solution: Motor homing error may indicate that the motor met some mechanical resistance and was unable to reach the proper home position. Check the home position using the handheld controller and re-home if necessary.

Solution: Motor offline error may indicate that the motor is not communicating with the line controller. Turn the power to the line off and wait 20 seconds to power on the line and re-calibrate.

5. **Problem area:** MKIV.

Solution: MKIV not ready error indicates that the MKIV is in a setup menu and needs to be returned to tag mode.

Solution: MKIV offline error indicates that the MKIV is not turned on or is not receiving power.

AutoFish Spare Parts Order List

★Sorter Parts

Part number:	Part	Description:
211-0513-01		1. Air Cylinder
211-0488-01		2. Wedge
216-0014-01	3.	Wire Gauge
210-0230-01		4. Sorter Calibration Gauge, 80mm
211-0487-01		5. Roller
212-1311		6. Socket Head Shoulder Screw (Qty 10)
211-0648-01		7. Wire Aperture (Pair)
211-0512-02		8. Divider Gate: Inside Divider (3.0")
211-0660-01		9. Divider Gate: Outside Divider (3.4")
212-1710		10. Flathead Phillips Screw (Qty 25)
211-0659-01A		11. Cylinder Mount Pin (Qty 5)
211-0634-02		12. Mount, Air Cylinder
211-0654-01		13. Cover, Cylinder Mount
212-1283		14. Washer, Flat #8 (Qty 25)
212-1339		15. Nut, Hex, 8-32 (Qty 25)
212-0250		16. Nut, Lock, Nylon Insert 8-32 (Qty 25)

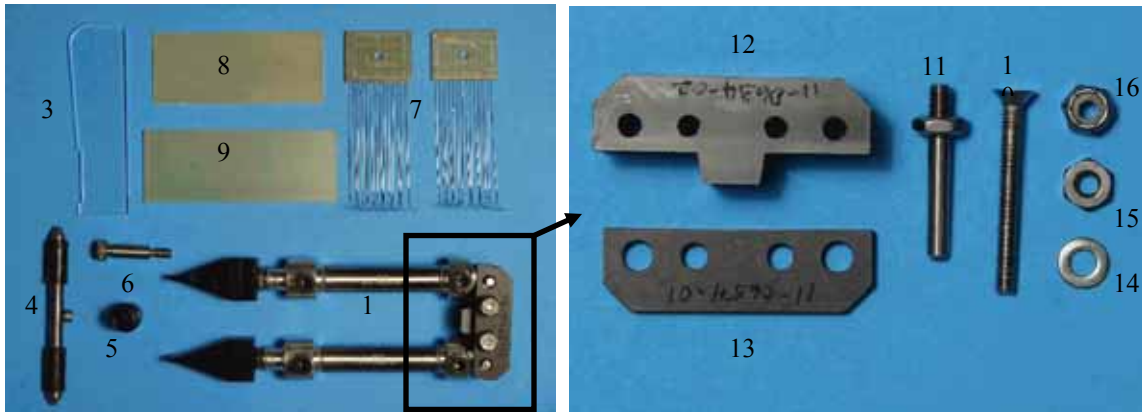

Figure 51: Sorter Parts

★Vision System

Part number:	Part	Description:
212-0076		1. CCD Camera (Line)
210-0205-01		2. Spinner Motor Assembly
210-0152-05		3. Cable Assembly, Camera Harness
210-0226-01		4. Spinner Assembly



Figure 52: Vision System

★Clipper Assembly

Part number:	Part	Description:
210-0199-02	1	Clipper Block Assembly
211-0153-03	2	Shaft Switch (Plunger) (Qty 5)
210-0225-02	3	Clipper Blade (51 large blades)
211-0123-02	4	Anvil (Qty 5)
212-0204	5	Flat Delrin Washer .065 ID (Qty 25)
211-0435-01	6	Bearing Spherical (Qty 10)
212-0161	7	Compression Spring .088 OD (Qty 10)
212-0223	8	Nylon Lock Nut 6-32 (Qty 25)
212-0164	9	Ext. Retaining Ring 1/8" Shaft (Qty 25)
212-0207	10	Ext. Retaining Ring 1/16" Shaft (Qty 25)
211-0828-01	11	Screw, Clipper Carrier (Qty 4)

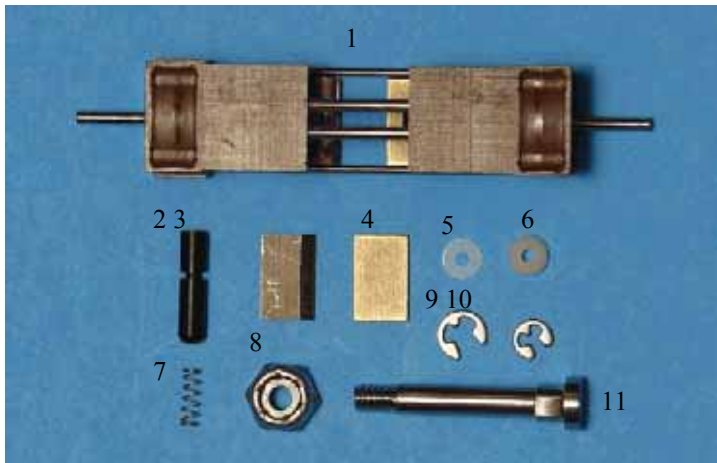

Figure 53: Clipper Assembly Parts

★Fish Adapter Plates Hardware

Part number:	Part Description:
211-0115-01	1. Left (outside) Clamp Plate
211-0118-01	2. Right (inside) Clamp Plate
212-0942	3. Socket Head Shoulder Screw (Qty 5) Holds the trapdoor assembly to the line control box
212-271	4. Socket Head Shoulder Screw (Qty 5) Holds the right (outside) adapter plate to the holder assembly
212-1368	5. Socket Head Captive Screw (Qty 5) Holds the right (inside) adapter plate to the holder assembly
212-1479	6. Hub Split Clamp Hub (Qty 5) Holds trapdoor on the hub
212-158	7. Socket Head Cap Screw (Qty 20) Fastens the trapdoor to the stepper motor assembly
212-206	8. Button Head Screw (Qty 20) Fastens the lower head mold to the trap door
212-1480	9. Curved Disk Spring (Qty 5) Keeps the trap door in horizontal alignment
212-0273	10. Flat Washer (Qty 25)
212-1180	11. Cone Point Set Screw (Qty 20) Fastens the pad assemblies to the adapter plates

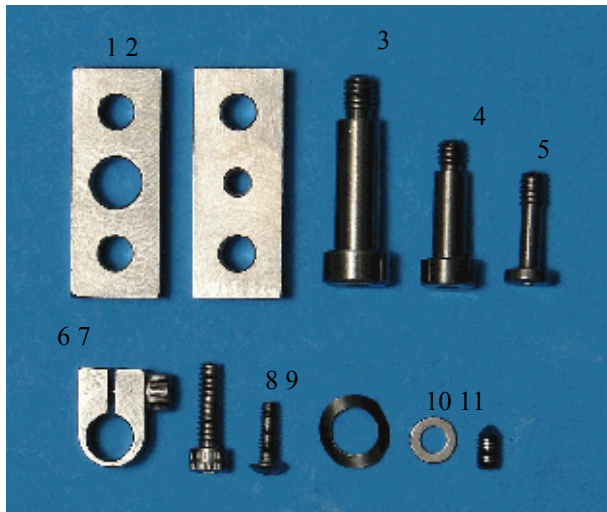

Figure 54: Adapter Plate and Trapdoor Hardware

★Fish Adapter Plates

Foam Pad Set of Left and Right (Qty 6)

Part number:	Part	Description:
210-0389-01	20fpp	left & right
210-0390-01	25fpp	left & right
210-0391-01	30fpp	left & right
210-0392-01	38fpp	left & right
210-0393-01	45fpp	left & right
210-0394-01	55fpp	left & right
210-0395-01	65fpp	left & right
210-0396-01	78fpp	left & right
210-0397-01	90fpp	left & right
210-0398-01		105fpp left & right
210-0399-01		120fpp left & right
210-0400-01		160fpp left & right
210-0401-01		200fpp left & right
210-0402-01		250fpp left & right

Belly Lifter Pad Set (Qty 6)

210-0403-01	20fpp	left & right
210-0404-01	30fpp	left & right
210-0405-01	45fpp	left & right
210-0406-01	65fpp	left & right
210-0407-01	90fpp	left & right
210-0408-01		120fpp left & right
210-0409-01		200fpp left & right

Each piece of the Fish Adapter Plates may be purchased individually including the head mold and trapdoor. Complete sets of Fish Adapter Plates are also available. Please contact NMT for part numbers and prices.

★Miscellaneous

Part number:	Part	Description:
210-0022-03		1. Home Sensor Cable
210-0025-03		2. Nose Sensor Cable Assembly
214-0017-09		3. PCBA, Stepper Interface
216-0013-01		4. Sensor Homing Tool
211-0024-02		5. Left Hand Gate Spring (Qty 10)
211-0025-02		6. Right Hand Gate Spring (Qty 10)
210-0017-02		7. Gate Mechanism Assembly
210-0035-02		8. Gate Channel Top Plate

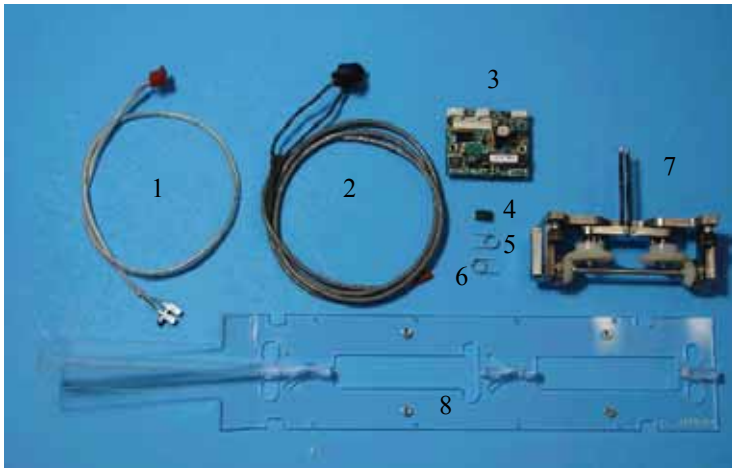

Figure 55: Miscellaneous Parts

★Accessories

Part number:	Part	Description:
210-0182-03		Handheld Fish Sizer
212-1015		Handheld Controller
210-0013-02		Cable Assembly (Handheld)
212-1507		5-Minute Gel Epoxy (1 oz.)
212-1263		Multi-Purpose Synthetic Lubricant

AutoFish Recommended Spares, Parts, and Accessories

These parts are not included with the purchase of an AutoFish trailer but are recommended for an efficient tagging operation.

- Spare drive rollers (MKIV assembly)
- Spare MKIV cutter
- Fin clipping scissors
- Fish identification (tag) sheets
- All weather spiral notebooks
- Copy paper
- Pencils
- Pens
- Clipboards
- All purpose scissors
- 2- Dip nets with 18" handle
- Dip net with 10' handle
- 2- 5 gallon buckets
- Thermometer
- MS222
- 16 ounce measuring bottle for handling MS222
- Alcohol
- PVP Iodine (1 gallon)
- Distilled water
- Bleach
- Polystyrene scrub brush
- Duct tape
- Vinyl electrical tape
- Cable ties
- Extension Cord
- Sharps container
- Scalpel blades #11
- Flashlight
- Utility knife
- Q-tips
- Cleaning supplies
- Paper towels
- Garbage bags
- Scotch Brite scour pads
- Earplugs
- Safety glasses
- Rubber gloves
- Half mask respirator

Appendix C
Index

A

Adipose Fin Clipping 71, 91
Align Camera 55, 93

B

Background Calibration 25, 29
Black Threshold 29
Blade Height Adjuster.....92
Booster Pump, Lines 64
Booster Pump, Sorter 41

C

Calibration, Line..... 56, 93
Calibration, Sorter 25
Clip Delay..... 54
Clipper Shimming 92
Coded Wire Tag (CWT)..... 97
Configure..... 52, 88
Control Density 28

D

Disinfection 109
Disinfect Mode, Lines 48
Disinfect Mode, Sorter 27
Diverter Safety Margin..... 26

E

Emergency Procedures 113
Errors 52, 59

F

Find Fin 57, 98
Fish Pump..... 38
Fish Pump Valve 28, 30, 38

G

Gain 29
Gates 65
Gradient Threshold 26

H

Hand Held Controller 85
Head Mold Simulator 76
Homing Motors 69

L

Lift Control 27
Line Controller 49
Line Controller PCB 66

M

Maintenance 105
Main Water Pump 13
Marker Speed 54
MKIV 75
Multiples 33

N

Nose Sensitivity 54, 87, 96

O

Override 53

P

Parolee 101
Push Down Steps 54

Q

Quality Control Check (QC) 97
Quality Control Device/ Diverter (QCD) 77

R

Region of Interest 24
Rejects 102
Review Images, Sorter 23
Rinsing..... 14

S

Sample Mode, Sorter 30
Shape Errors 33, 96
Simulation 55, 94
Sorter Data 32
Sorter Port Adjustments 18
Sorter Setup 24
Stepper Motor 67
Stepper Motor Driver 68
Stepper Motor Interface..... 68
Supervisor..... 47
System Feed 21

Tag Failure 100
Test Ports 26
Trigger Sensor 27
Troubleshooting..... 115

Uninterrupted Power Supply (UPS) 12
Unsafe Holds 33, 95

V

Valve Box..... 42
Verify Mark..... 58, 99
Vertex 29
Voltage Sensing Relays..... 12

W

Water Jet Aperture..... 44
Wire Aperture..... 44

Appendix D

Contacting NMT

NMT strives to provide the highest quality tagging systems for fisheries research and management. We offer free consultation on the suitability of available methods for specific purposes.

Technical Support:

For answers to technical questions about the AutoFish technology, please contact:

Brian Toews
Field Technician
AutoFish Systems Specialist
Cell: (360) 770-3606
Fax: (360) 299-2970
E-mail: brian.toews@nmt.us

Joel LaHaie
Research Biologist
AutoFish Systems Specialist
Cell: (360) 870-7710
Fax: (360) 596-9405
E-mail: joel.lahaie@nmt.us